



Supercharger Installation Manual

2010-2011 Chevrolet 6.2L Camaro



WHIPPLE SUPERCHARGERS
3292 NORTH WEBER AVE
FRESNO, CA 93722
TEL 559.442.1261
FAX 559.442.4153

www.whipplesuperchargers.com
A color PDF of this manual is available email
tech@whipplesuperchargers.com

PREMIUM FUEL ONLY (91 OCTANE OR BETTER ALWAYS) RON+MON/2

CALIFORNIA AIR RESOURCE BOARD EXECUTIVE ORDER #D-231-32

Introduction

Before beginning installation, we encourage you to read this manual thoroughly before you begin any portion of the installation:

1. A quick parts check to make certain your kit is complete (see shipper parts list in packing paperwork). If you discover shipping damage or shortage, please call our office immediately.
2. Review our limited warranty with care.
3. Always wear eye protection during installation.
4. Avoid spills, if one occurs, clean up and dispose of towels properly.
5. Never work on a hot engine.
6. Obey all traffic laws when testing the vehicle.

Recommended Tools and Supplies

The following items are not included in this supercharger kit and it is strongly recommended that they're used for ease of installation or maximum performance:

Torque Wrench

1/4", 3/8" and 1/2" torque wrenches are required during installation.

Tools

Safety glasses, metric wrench set, assorted drill set, electric or air drill, 1/4", 3/8", 1/2" assorted metric socket set, 3/8" assorted metric allen socket set, 3/8" assorted torx socket set, 8mm hex allen wrench, 1/2" breaker bar, flat head and phillips screw drivers and drain pan (for coolant).



Tie Straps

These will be useful for securing the wiring harness away from the installation area as directed in the

Illustrated Installation Guide. They are inexpensive and will be very handy during installation.

Sealants

Blue Loctite™ #242 or equivalent, Red Loctite™ #271 or equivalent. All bolts that need Loctite™ are marked with:

 **Loctite™ (#242 blue) threads** and  **Loctite™ (#271 red) threads**. Thread sealant such as pipe Teflon must be used on all pipe threads.

Chemicals and lubricants

You will need some cleaner/degreaser such as carb cleaner.

You'll be required to fill your intercooler system with approx. 1 gallon of distilled water and GM approved engine coolant. This is not supplied in the system, you can find the coolant at any local auto parts store. NEVER USE TAP WATER, as it can corrode and create poor performance.

Motor oil will be useful as a lubricant and should be readily available during installation.

Vacuum

A vacuum is necessary to clean up any debris resulting from grinder use.

Clean Shop Towels

Use these to keep the installation area clean.

Pre-Installation Checklist

Before installing your Whipple Supercharger Kit, complete the following checklist.

!! CAUTION !!

Failure to complete the Pre-Installation Checklist may result in severe engine damage after installation is complete.

1. Verify Condition of Vehicle: Before the supercharger kit is installed, ensure the engine runs smoothly and that the factory malfunction indicator light (MIL) is off. Only install the supercharger kit if the engine runs smoothly *and* the MIL is off.
2. **!! CAUTION !!**
This product is intended for use only on STOCK, UNMODIFIED, WELL-MAINTAINED engines. Installation on a worn-out or modified engine is not recommended without factory computer and fuel system modifications. Custom engine configurations could require custom tuning and other supporting modifications.
3. **!! CAUTION !!**
Use only 91 octane fuel or higher. If fuel of less than 91-octane is present in the vehicle fuel tank, the tank must be completely drained and refilled with 91 or higher octane to 1/8th of a tank.
4. Verify Fuel System: Supercharger systems should only be installed on vehicles that have new or clean fuel filters.
5. Assess Cleanliness of Installation Area: Make sure your work area and the under hood area are free from debris. This supercharger is a high-quality, close-tolerance compressor and must not be subjected to contamination by dirt or any type of foreign material. If necessary, vacuum around engine to remove any foreign material.
6. **!! CAUTION !!**
DO NOT remove the protective seal on the supercharger prior to installation. Foreign material entering the supercharger will automatically void all warranties.
7. Identify Supercharger Kit Components: Before beginning installation, identify all the components of your Whipple Supercharger Kit and ensure all items are present and undamaged.
8. Read
- 9.
10. Illustrated Installation Guide: Be sure to read through the
- 11.
12. Illustrated Installation Guide starting on page 6 *before* beginning supercharger installation. Familiarize yourself with the components and tools you will use and the procedures before you start for faster and easier installation.
13. **!! CAUTION !!**
Do not attempt to start the engine before adding the supplied Supercharger Oil to the supercharger!

Pre installation inspection with Scan Tool (Verify Condition of Vehicle)

It is advised to inspect the vehicle before installing the Supercharger kit if any problems are found it is easier to deal with them before the supercharger is installed.



1. Please unpack the supercharger kit and locate the Superchips Flashpaq downloader.
2. Go to page 17 of the Flashpaq instructions booklet, found in Superchips box.
3. Read the DTCs and data from the ADVANCED FEATURES prompt.
4. The car that you are installing the supercharger on should have NO stored trouble codes. (IF VEHICLE HAS A STORED TROUBLE CODE OR HAS A DRIVEABILITY PROBLEM THIS SHOULD BE ADDRESSED FIRST.
5. The first data to be inspected is the LONG FUEL TRIMS. This data is a direct correlation of the air/fuel mixture. PERFECT long fuel trims are 0 (this means the ECM is adding no fuel OR not subtracting fuel. In the REAL world the fuel trims -2 to +8 are considered to be correct).
6. With the engine warmed up at idle Inspect long fuel trim Bank 1 (1,3,5,7) and long fuel trim Bank 2 (2,4,6,8), if the data is within -2 to +8 this is normal.

Symbol Key

Throughout this installation guide you will see the following symbols used:

➤ NOTE

Used to indicate tips and information to aid in installation, maintenance, or use of the supercharger.

!! CAUTION !!

Used to indicate precautions that must be taken to avoid damage to the supercharger and associated components.

⚠ WARNING!!

Used to indicate precautions that must be taken to avoid bodily injury as well as damage to the supercharger and associated components.

Supercharger Installation Instructions

Vehicle: Chevrolet Camaro Engine: LS Series 6.2

Before you begin installing the Whipple SC system, make sure you have completed the **Pre-Installation Checklist**. Be sure you have:

1. Verified the Condition of the Vehicle
2. Verified the Fuel Octane is 91 or higher
3. Verified that the fuel system is clean
4. Assessed the Cleanliness of the Installation Area
5. Identified the Supercharger Kit Components
6. Read and Understood the

Illustrated Installation Guide

- Have you completed all items in the **Pre-Installation Checklist**?

➤ NOTE

****NOTICE:** *Installation of Whipple Supercharger products signifies that you have read this document and have agreed to the terms stated within.*

It's the purchaser's responsibility to follow all installation instruction guidelines and safety procedures supplied with the product as it's received by the purchaser to determine the compatibility of the product with the vehicle or the device the purchaser intends to install the product on.

Whipple Superchargers assumes no responsibility for damages occurring from accident, misuse, abuse, improper installation, improper operation, lack of reasonable care or all previously stated reasons resulting from incompatibility with other manufacturer's products.

There are no warranties expressed or implied for engine failure or damage to the vehicle in any way, loss of use or inconvenience or labor reimbursement. This includes merchantability and fitness.

NEVER SMOKE DURING THE INSTALLATION OF THE SC, THERE WILL BE FLAMMABLE FUMES AND LIQUID AROUND THE VEHICLE

Be sure you have read and understand the pre-installation checklist the **Pre-Installation Checklist**, then proceed to the

Illustrated Installation Guide.

Illustrated Installation Guide

It is strongly recommended that you read through this guide before you begin installing the Whipple Supercharger.

1. Using an air hose, blow off any loose dirt or debris from engine compartment. If really dirty, then steam clean the engine compartment before proceeding to the next step.

 WARNING!! Batteries normally produce explosive gases. Therefore, do not allow flames, sparks or lighted substances to come near the battery. When charging or working near a battery, always shield your face and protect your eyes. Always provide ventilation. Failure to follow these instructions may result in personal injury.

 WARNING!! Keep out of the reach of children. Batteries contain sulfuric acid. Avoid contact with skin, eyes or clothing. Also, shield your eyes when working near the battery to protect against possible splashing of the acid solution. In case of acid contact with the skin or eyes, flush immediately with water for a minimum of 15 minutes and get prompt medical attention. If acid is swallowed, call a physician immediately. Failure to follow these instructions may result in personal injury.

2. Take the programmer and with the instructions, found in Superchips box turn to page 8 for programming instructions, program the ECM/TCM.

 WARNING!! To avoid any problems with the Whipple supercharger kit and Superchip we recommend you have the Camaro computer updated at GM to the most current operating system before installing the supercharger kit.

- Your computer must have a stock unaltered file or programmer will not load.
- If you car has been tuned you will need to return it to stock before proceeding
- If you're unable to return it to stock you will need to take it to a GM dealer and have them update the computer.

If you have problems or questions about the Superchip Programmer please call Whipple tech support 559-442-1261.

DISCONNECT BATTERY:

3. Open the trunk and remove the trunk liner & Remove the battery cover by unscrewing the plastic lid retainer.



4. Remove the air compressor assembly, then Remove the NEGATIVE battery connector with a 10mm wrench. The battery cable MUST remain off for the remainder of the install.



INTERCOOLER HEAT EXCHANGER INSTALLATION:

5. Jack up the vehicle and remove both front tires. NOTE: Please install correct jack stands and be VERY careful.



6. Remove both plastic inter fender wells to gain access to the front mounting bolts by removing screws and retainers



7. There are 5 TORX screws and 5 push in retainers, 3 screws in front , 2 on the back side, 2 push-in retainers in front and 1 in top and 3 on the backside.
8. Remove 6 push-in retainers on the top of the Fascia and 4-10mm bolts.



9. There are 2-10mm bolts on bottom of the fascia.



10. There are 2- TORX and 3-10mm bolts on each side holding the fascia to the body.

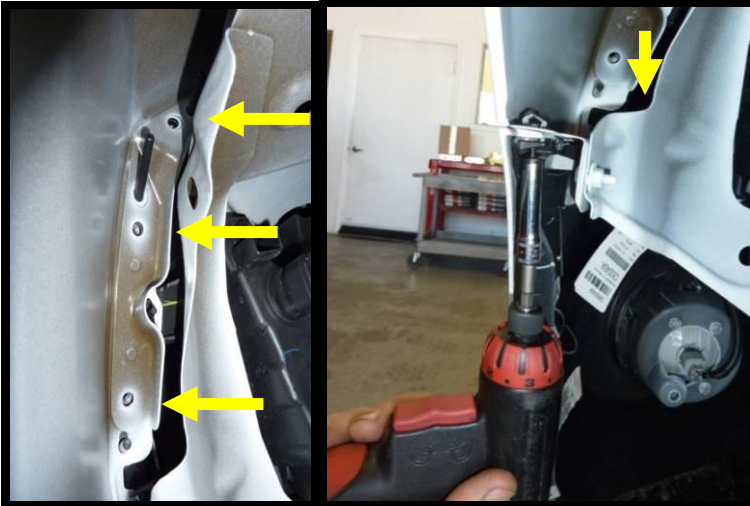

11. Unplug the master electrical connector on the passenger side wheel well.



12. Remove the Fascia by pulling straight forward (having some assistance will help). Place Fascia in a safe place.



13. Locate all the heat exchanger parts. (2) heat exchanger brackets, water pump, heat exchanger assembly, all hoses (ALL hoses are precut and the clamps are on the ends) and the pump electrical relay assembly.



2010 Camaro Intercooler hose routing
hose Part #'s
splice size & location

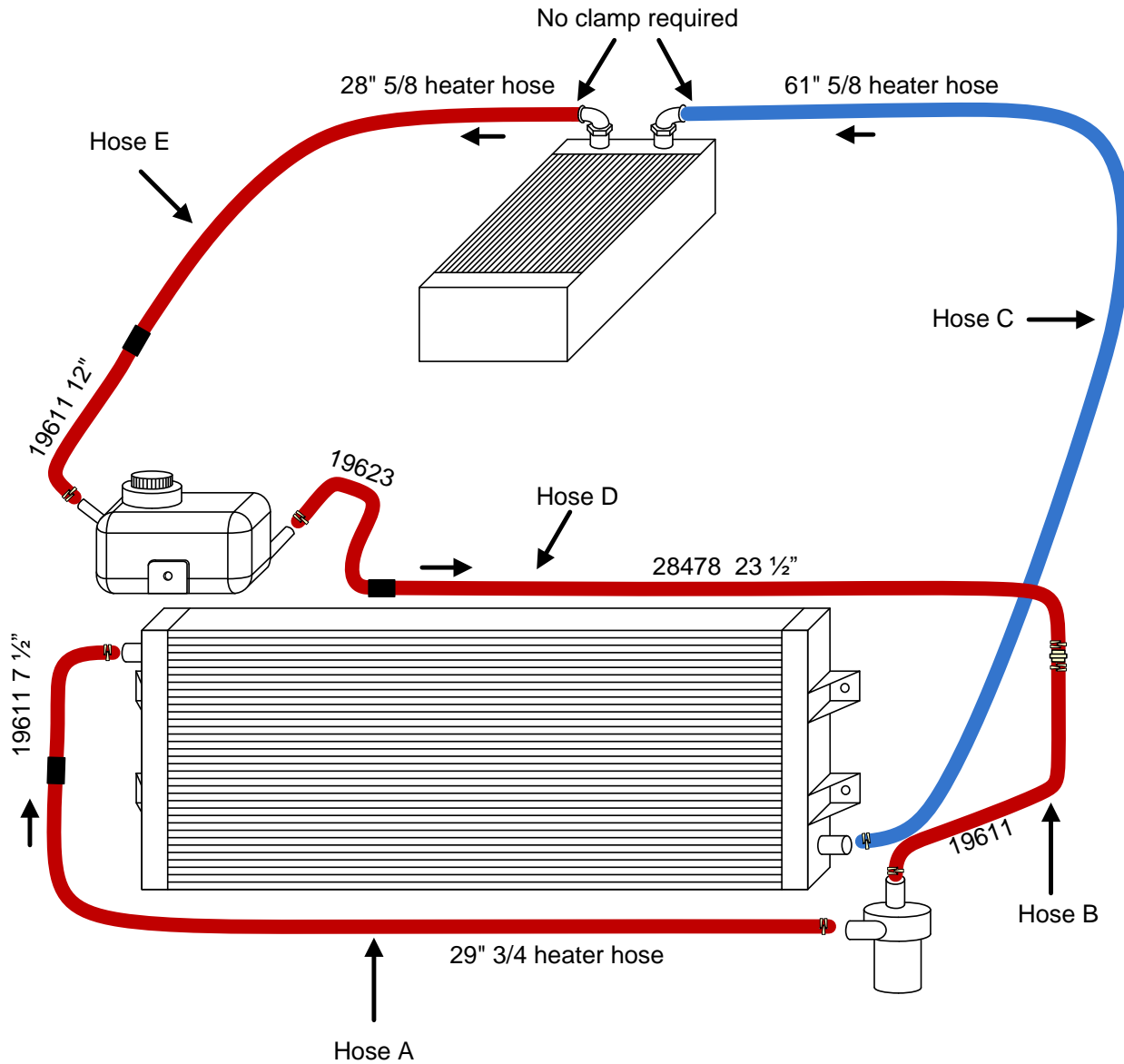

14. Remove the retainers from this shield. The shield and the retainers will not be reused.



15. With a saw remove the ends of the lower radiator mounts. (To gain access to the lower hole.) Cut both plastic corners like the photo.

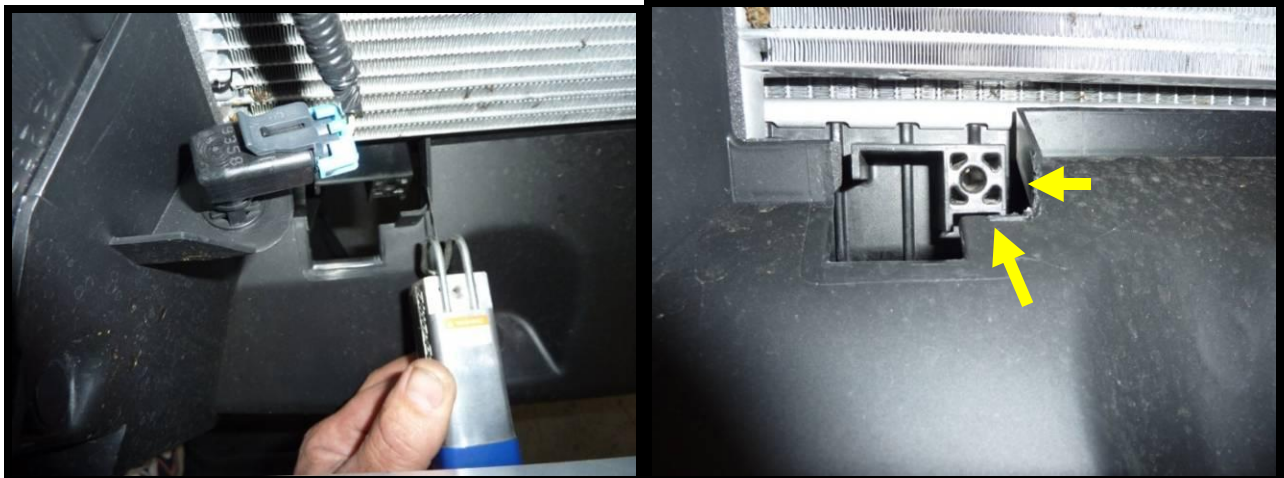

16. Tap both lower radiator mounts with the provided 8 x 1.25 tap. Insert the tap approximately 1.0 inch.

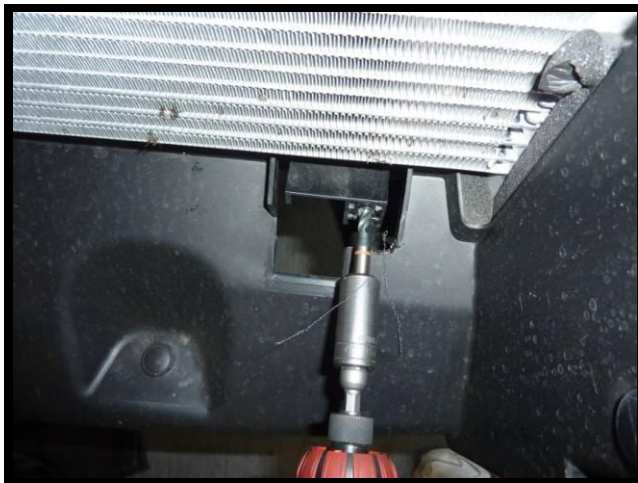

17. Install the passenger side heat exchanger with a M8 x 25mm bolt on the lower mount.



18. Make sure bracket is straight BEFORE you drill the 5/16" hole in the upper radiator support. (NOTE: DO NOT DRILL INTO THE ELECTRICAL HARNESS BEHIND THE SUPPORT).



19. Install the drivers side heat exchanger bracket (this bracket has the water pump mount) with a 8mm x 25mm bolt. Drill a 5/16" hole in the support. (DO NOT DRILL INTO ELECTRICAL HARNESS BEHIND SUPPORT).



20. Pre- Install the intercooler water pump with (2) M8 x 25mm bolts, washers and nylock nuts. Do not tighten bolts fully.

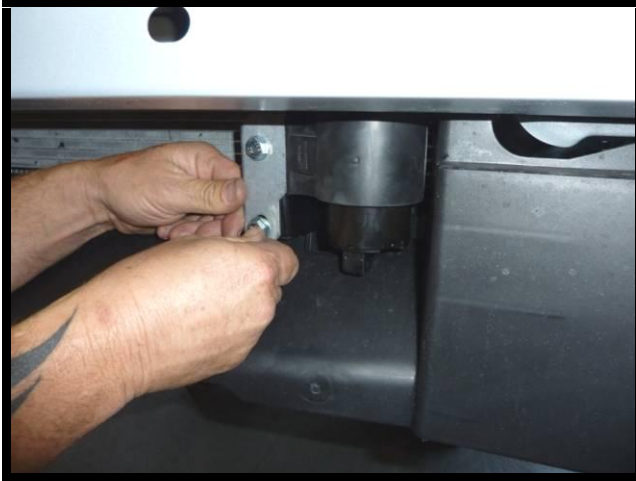

21. Mark a location on the lower plastic filler for the hole that the intercoolers pump connector to go through.



22. Remove intercooler pump and with a 1.0 inch hole saw drill the marked location. Reinstall intercooler pump assembly.



23. With a 4.0 inch hole saw drill the plastic filler panel. (This hole is to allow fresh air into the airbox area).

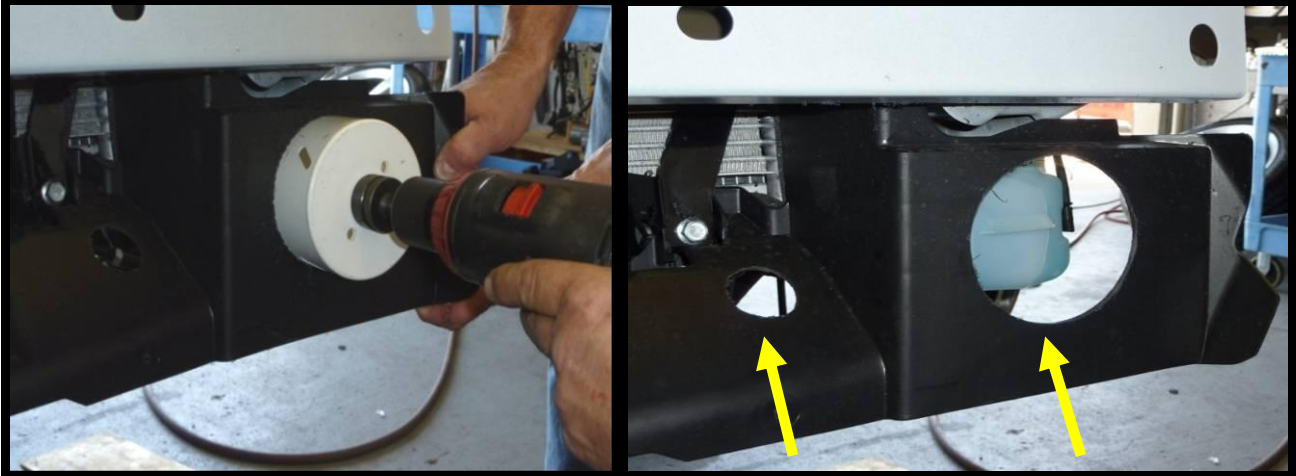

INTERCOOLER PUMP RELAY HARNESS:

24. Install Intercooler harness, locate the electrical component bag and take out the intercooler harness mount relay as shown on right hand side of radiator support, with screws provided.



25. Route intercooler pump harness down under radiator across support and plug into pump.

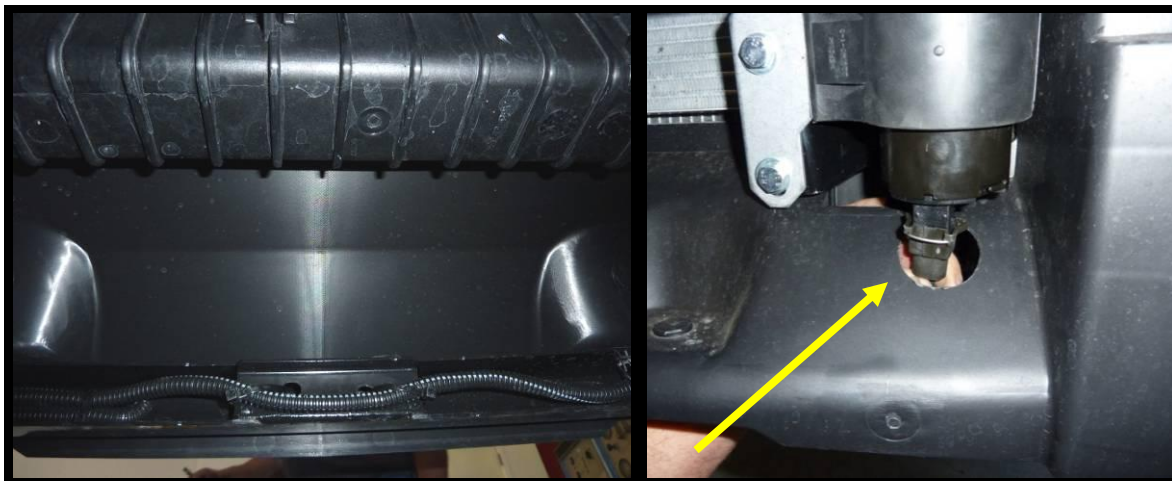

26. Connect red power lead to stud at front of fuse box.



27. Remove fuse from position 15 and insert it into fuse tap then Insert fuse tap into position 15.



28. Route ground lead along frame rail then up onto engine on right hand side to ground stud above thermostat and bolt down.

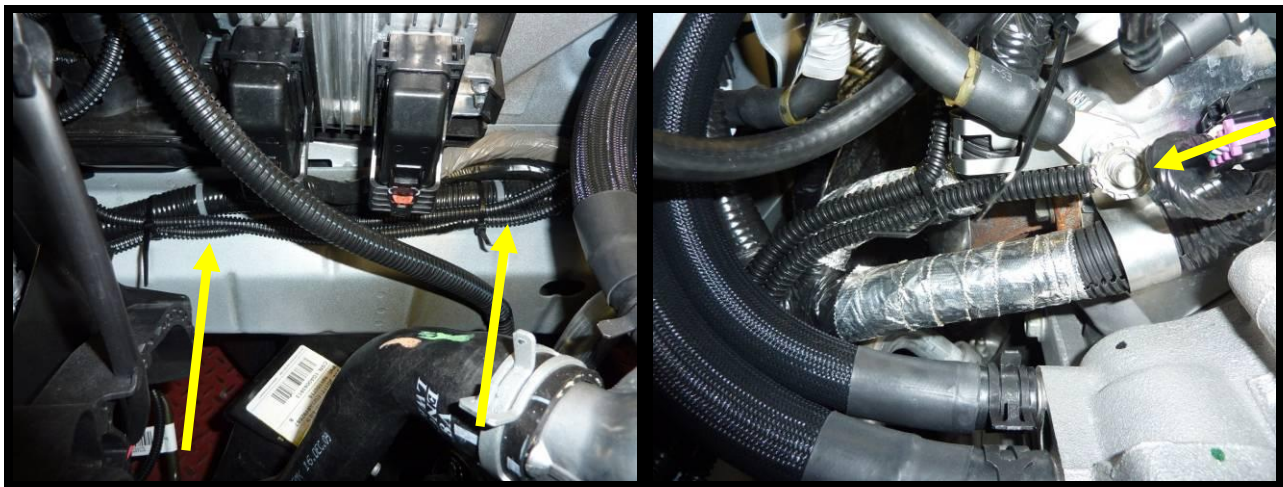

29. Notch out the edge of the fuse box lid so the wires can pass through



30. Intercooler harness complete.

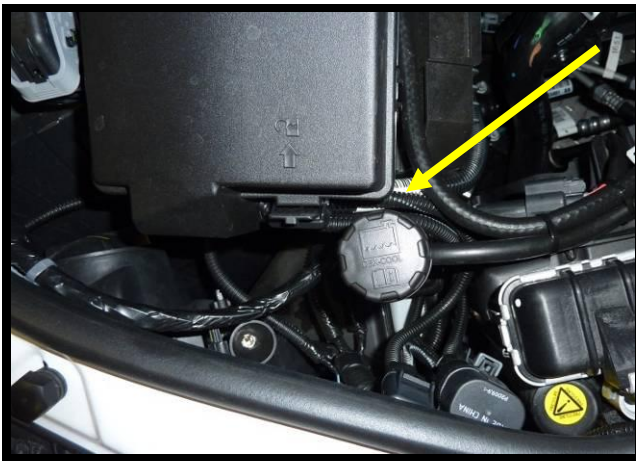

AIR BOX REMOVAL:

31. Unplug the PCV vent tube from the air duct. Pull straight out on the tube.

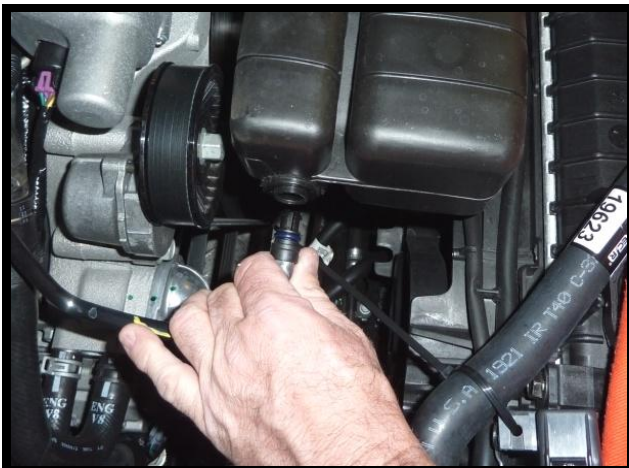

32. Remove the plastic duct by loosening the 2-5/16 hose clamps. This will NOT be reused.



33. Remove the upper air box. By unsnapping the 2 plastic tabs. Remove the air filter, it will be replaced with a high flow K&N, Remove the lower air box by removing the (2) 10mm nut and pulling the box up .NOTE: Be careful not to tear the foam around the inlet.

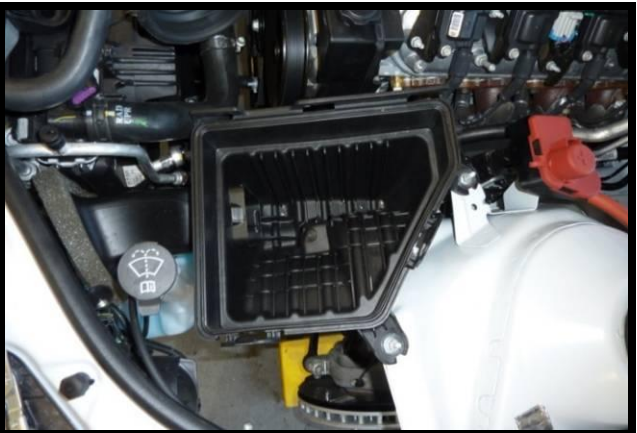

INTERCOOLER HOSE INSTALLATION:

NOTE: ALL HOSES ARE PRE-CUT TO CORRECT LENGTH, and the CLAMPS are on the HOSE ENDS.

34. Install the passenger side 3/4" hose (A) from the intercooler pump. Allow hose to lay in the plastic filler panel for now. Install hose (B) from inlet of pump to the intercooler reservoir.



35. Install the heat exchanger with (4) counter sunk (M8 x 35mm) bolts and washers and nylock nuts. NOTE: There are (2) sizes of outlets on the heat exchanger 5/8" and 3/4" the 5/8" end goes on the DRIVER side.



36. Install other end of hose (A) 3/4" on passenger side inlet fitting. (This was the hose laying in the plastic filler).

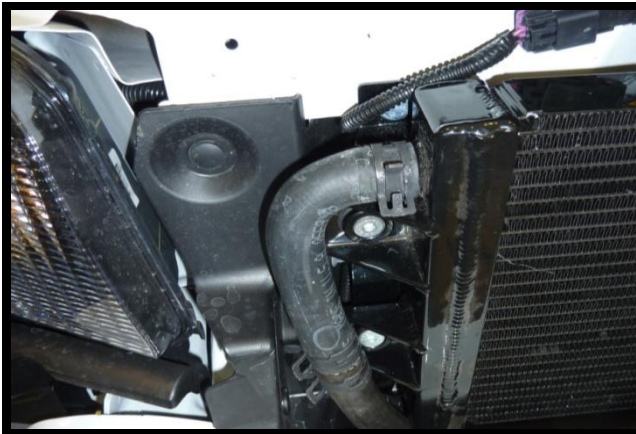

37. (Hose C) This outlet is the 5/8" discharge outlet to the intercooler core Install hose (C) 5/8" x 61" hose from the intercooler discharge to the -10 AN hose fitting at the intercooler core.



38. (Hose C) route down the OUTSIDE of the A/C line. **NOTE:** If you run it down the INSIDE of the line you cannot reinstall the airbox.



39. Finished heat exchanger installation.



40. Reinstall the front bumper fascia assembly.
- Torque the front fender support bracket screw to (62 inch pounds).
 - Torque the front bumper fascia outer bracket nut to (62 inch pounds).
 - Torque the front bumper fascia bolt to (27 inch pounds).
 - Torque the front bumper fascia lower bolt to (62 inch pounds).
 - Torque the front bumper fascia lower screw to (62 inch pounds).
 - Reinstall the 6 push- in retainers.
 - Note: Don't forget the 2 lower 10mm bolts.

FACTORY INTAKE MANIFOLD REMOVAL:

41. Remove the PCV vent tube by unclipping the release tab. This tube will NOT be reused. Pull the release tab down to allow the connector to release.



42. Unplug the purge solenoid, MAP sensor and the Electronic Throttle Control connectors.



43. Unplug the purge vacuum hose. Push in the lock tab to release the connector, then unplug the other side of the vacuum hose from the intake manifold. This hose will be reused.

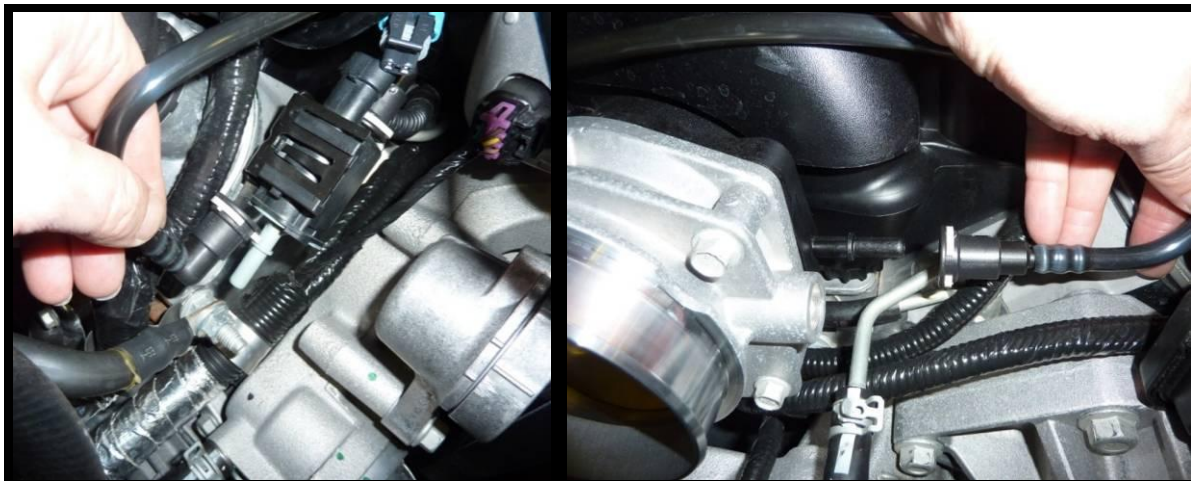

44. Unplug the purge tank vacuum hose assembly. Put this vacuum hose over by the Antilock Brake Module for now.

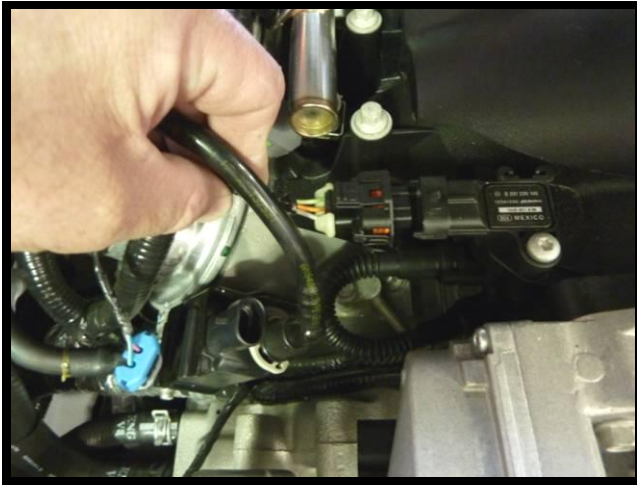

45. Remove the 10mm nut that retains the fuel line.



46. Remove the plastic retainers from the fuel line. Remove the secondary lock retainer.

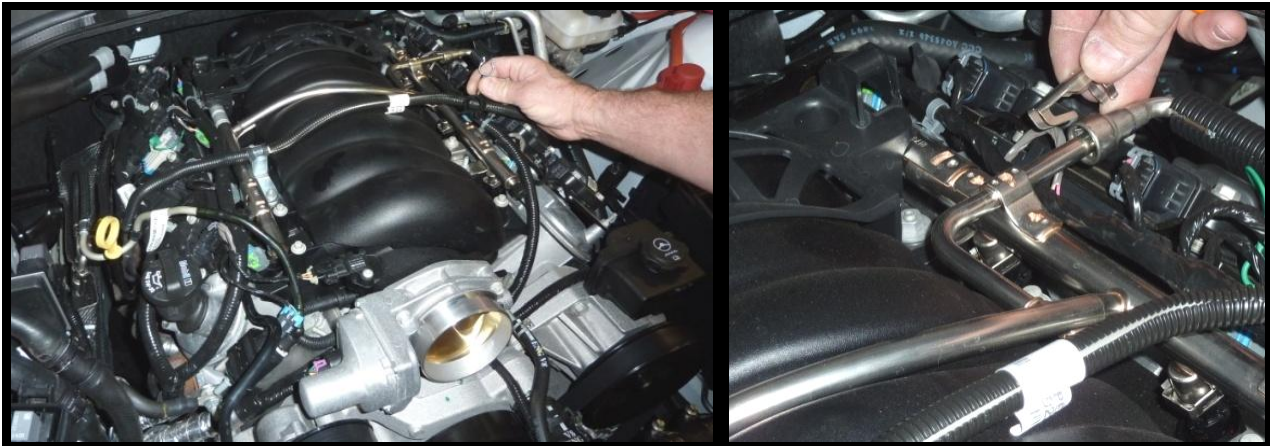

47. Install the 3/8 plastic rail tool on the fuel line.

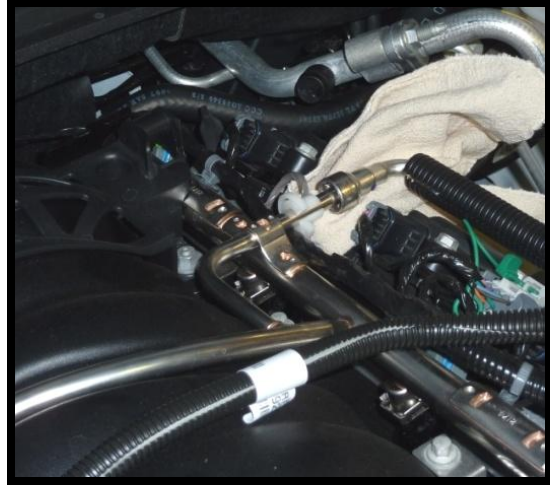
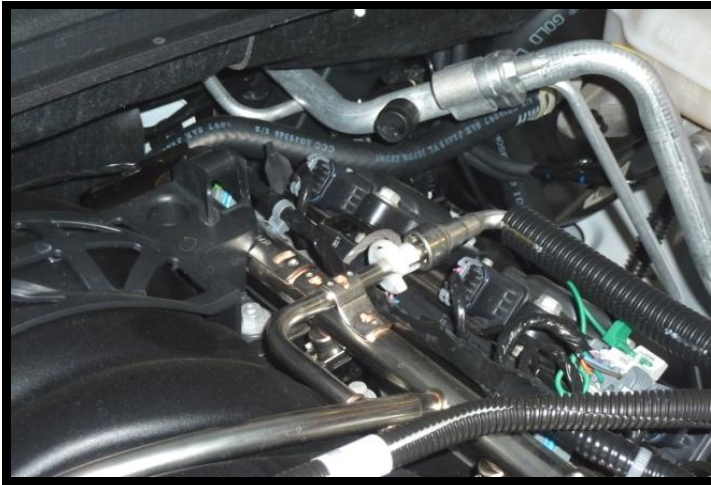

48. With a rag to retain the spilled fuel, push the fuel release tool into the connector and release the connector. **NOTE:** This fuel is UNDER PRESSURE BE VERY CAREFULL.



49. Remove the secondary lock from the chassis fuel line. Install the fuel line release tool and release the connector **NOTE:** Place a rag to retain spilled fuel from the line, remove the line It will not be reused



50. Remove the (2) injector harness retainers from the fuel rails then unplug the passenger side 2,4,6 and 8 injectors by pulling up on the secondary lock then depress the middle tab. swing the harness out of the way for now.



51. Release the 2 harness retainers on bank 1 and unplug drivers side 1,3,5 and 7 injectors.
52. Unplug the main coil electrical connector and remove the sparkplug wires from coils on bank 1. **NOTE:** Be careful not to damage the sparkplug wire. Remove (5) 10mm bolts from the coil pack mounting points and Remove the coil pack from the engine.

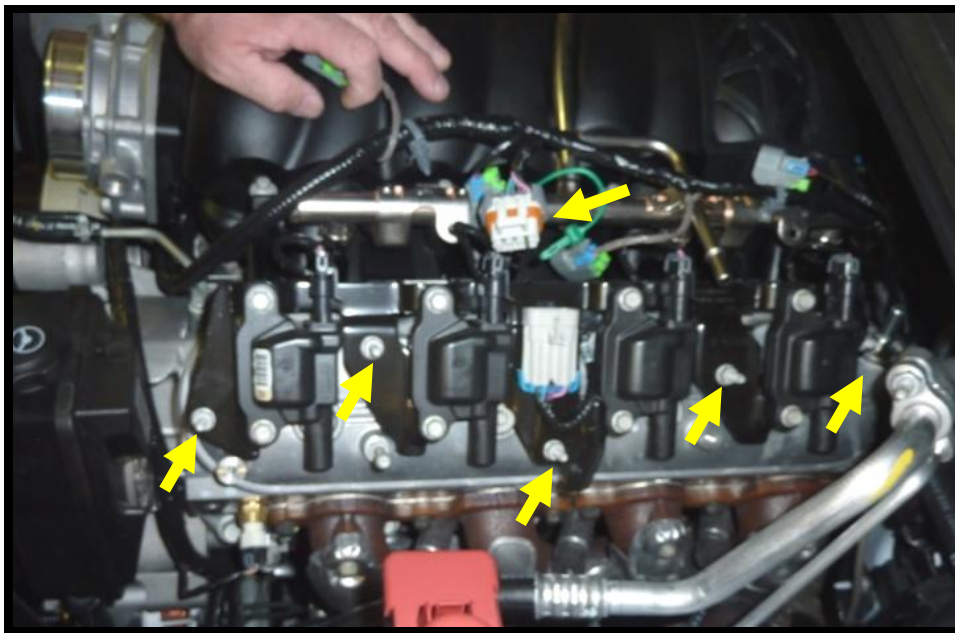

53. Remove the main coil electrical connector from bank 2. Remove the (5) 10mm bolts, remove all the sparkplug wires and remove the coil pack.
54. Remove the brake hose vacuum check valve from the brake booster.



55. Remove all (10) of the intake manifold retaining bolts. (8mm socket)



56. Remove the 10mm retaining nut from the engine cover mounting bracket and remove the bracket.



57. In the supercharger kit there is (2) small pieces of conduit to install on the rear (2) bolts to allow them to be removed with the intake manifold. NOTE: There is NOT enough room to remove the bolt from the manifold and if you leave the bolt in it will hang on the cylinder head when you remove the intake manifold.



58. Remove the lower vacuum hose by releasing the tab on the hose connector. It's on the **BOTTOM** of the hose.

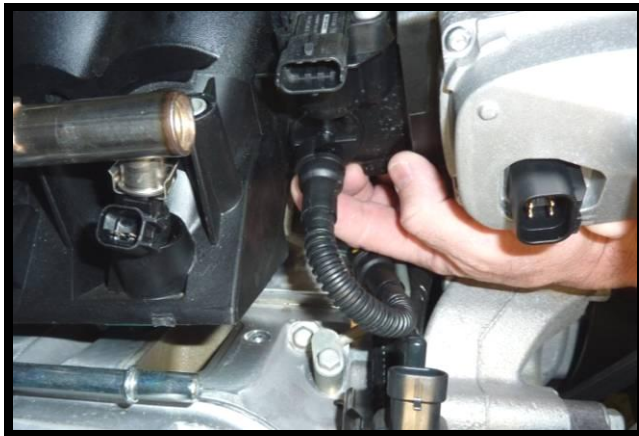

59. Remove the intake manifold by swinging the manifold to the drivers side and holding the brake vacuum hose. **NOTE: DO NOT** allow the hose to get caught on the oil pressure sensor in the rear of the engine.



60. Remove the stock drive belt & belt tensioner by removing the (2) 15mm bolts. The bolts **WILL** be reused. The stock tensioner & belt will **NOT** be reused.

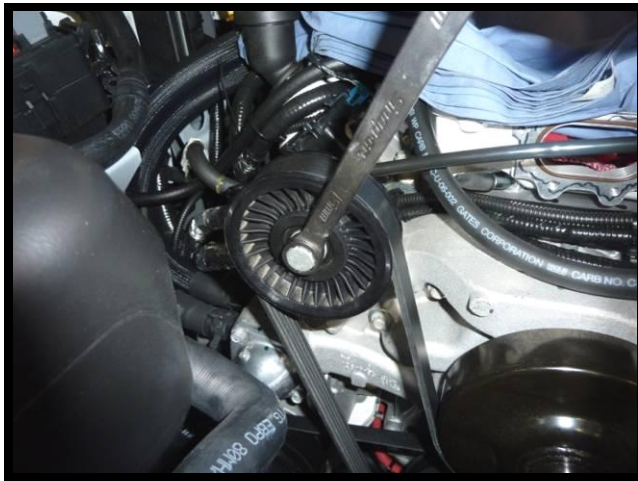

61. Remove the valley vacuum hose and tape up all the intake ports.



62. Remove all the stock sparkplugs & replace with a NGK Iridium IX TR7IX. Gap the sparkplug at .035". Torque the sparkplug to 11 foot pounds as per GM manual. NOTE: Apply a small amount of anti-seize on the threads.



HEATER HOSES AND THERMOSTAT INSTALLATION:

63. Remove the radiator cap then drain the radiator from the petcock into a clean drain pan.

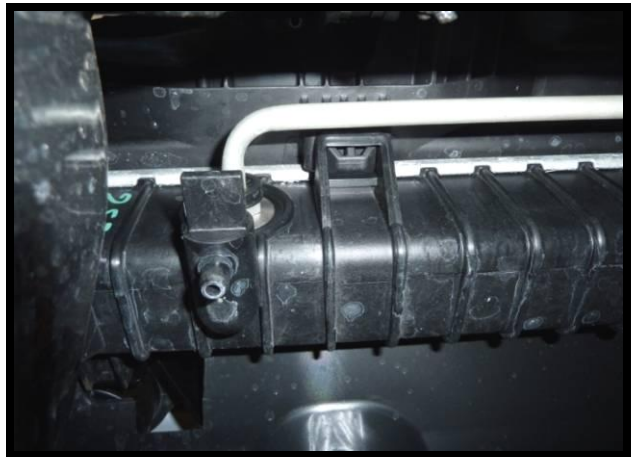

64. Remove both stock heater hoses. NOTE: BE VERY CAREFULL of the outlets. The clamps are glued to the hose.
- Remove the inboard hose first, it allows clearance to release the outboard clamp.
 - Then remove heater hose from water pump housing.



65. Compress the lower radiator hose clamp and remove the hose. The clamp is glued to the hose. Remove the (2) 10mm bolts from the thermostat housing and replace the thermostat with the supplied thermostat. Torque the bolts to 11 foot pounds.



66. Install the new heater hoses. One hose is 5/8 and the other is 3/4". Both hoses are precut and have the clamps on the hoses. Route the hoses between the dipstick tube and the oil fill.



67. Remove both the upper coolant fan assembly screws. (13mm socket).

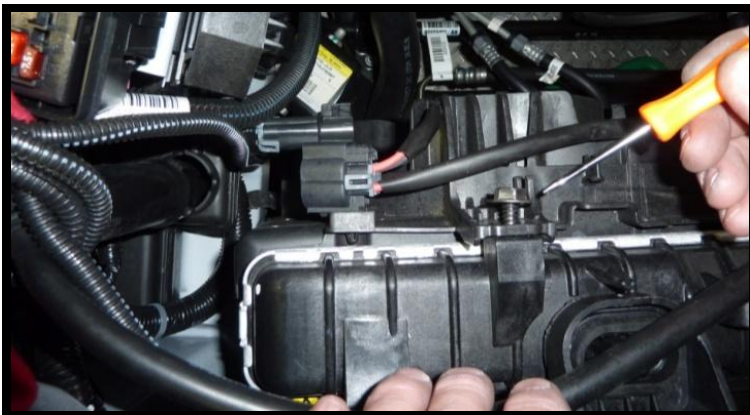

68. Remove both of the upper hoses from the filler neck. Remove this hose from both outlets. It will be reused later in the install.



69. Remove both 10mm bolts from the water crossover tube and remove stock coolant air bleed pipe. The stock pipe will NOT be reused.



70. The replacement coolant air bleed pipe has an oring in each end, Make SURE that the o ring is in the groove BEFORE you install the coolant air bleed pipe. Place coolant air bleed pipe on engine block and install both bolts torque each end to 106 inch pounds.

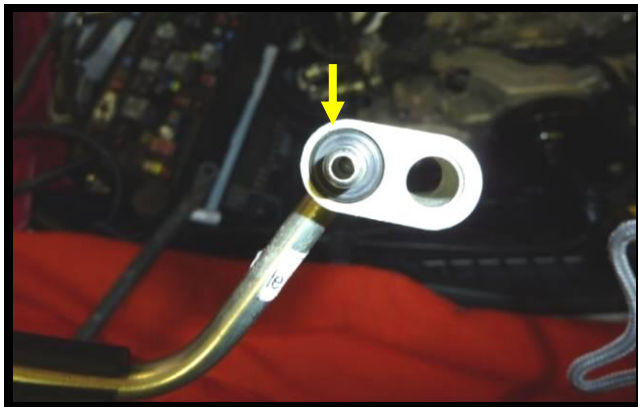

71. Remove the upper radiator hose from the radiator. This makes clearance so you can remove the fan assembly.

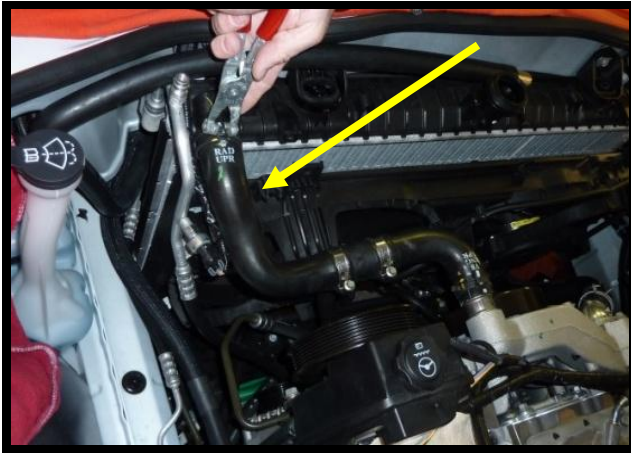

72. Unplug the fans electrical connector and remove the fan assembly.

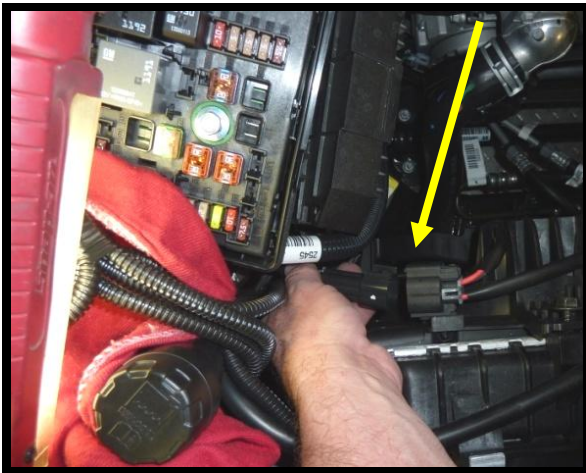

PINNING THE CRANK PULLEY:

73. Remove the factory bolt from the harmonic balancer (24mm socket). This bolt is VERY tight. You may need to HEAT the area AROUND the head of the bolt (NOT the head of the bolt) with a propane torch. NOTE: BE VERY CAREFULL OF AN OPEN FLAME AROUND THE ENGINE AND THE CHASSIS.



74. After removing the bolt clean the area with a solvent and blow dry with air.

75. In the supercharger kit you will find a Harmonic Balancer Pin Kit. Install the 14mm allen bolt into the drill guide and tighten the bolt hand tight

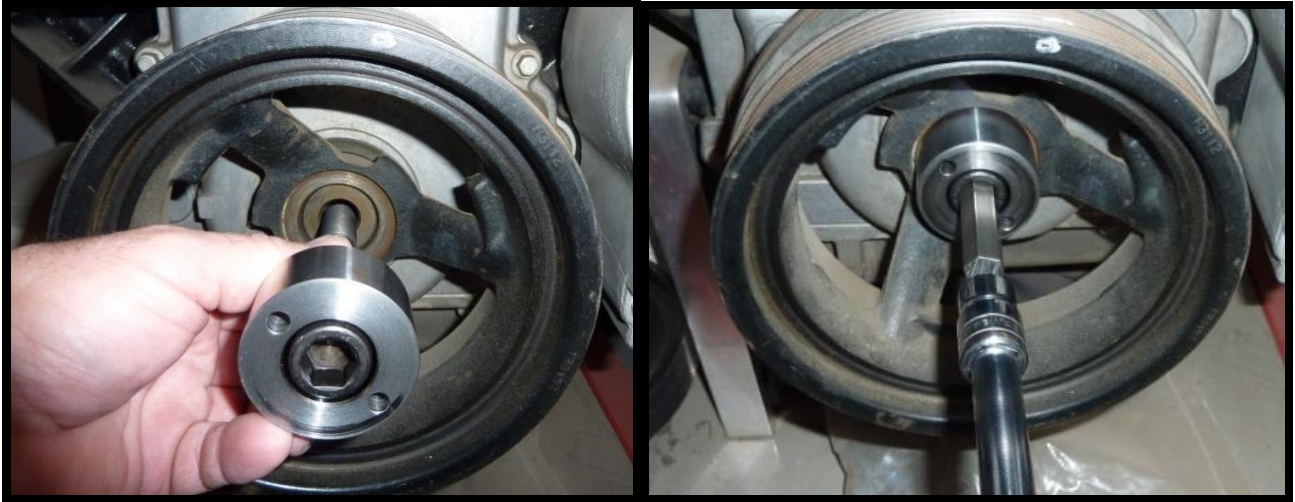

76. With the provided 2.0" x 14mm HEX stock and a 14mm 1/2" drive socket, tighten to 35 foot pounds.
77. Using the provided .250 drill bit, drill the hole until the collar touches the drill guide. **NOTE:** Clear the chips when drilling the hole, after drilling both holes blow all the chips out of the holes. **NOTE:** USE EYE PROTECTION.



78. Remove the drill guide and again blow away any loose chips then clean the area with solvent and blow dry.



79. Install both .251" dowels into the holes. NOTE: Make sure that when the dowel is installed it is LOWER than the HARMONIC BALANCER. The dowel should NOT touch the harmonic balancer when INSTALLED.

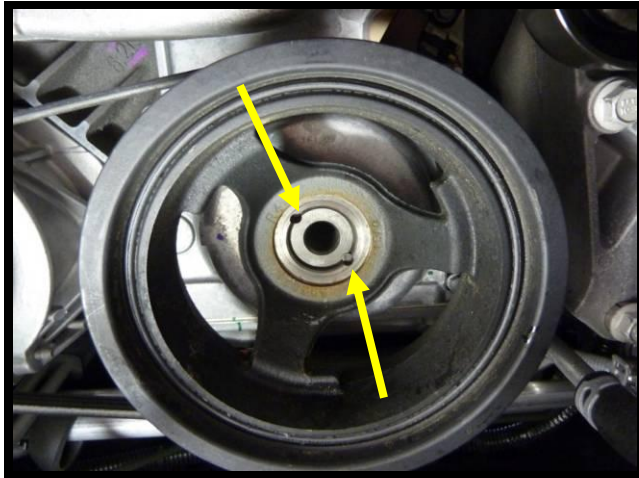

80. Install new ARP balance bolt Lube the washer and under the head of the bolt with APR assembly lube. Apply lube to BOTH sides of the washer. Apply a .020" bead of RED Loctite to the CLEAN threads.



81. Install the M16-20 ARP bolt using a 1 1/16" 12-point socket. Torque to 240 foot pounds. **NOTE:** On the 6 speed car apply parking brake, shift car into 4th gear and have a assistant apply the brakes to torque the bolt. On the automatic transmission car unbolt the starter and install GM Kent-Moore #J42386-A Flywheel Holding Tool to torque bolt.



82. When done with pin kit, re-install fan assembly. Make sure you plug in the power.
83. Reinstall upper radiator hose.
84. Remove the Brake vacuum check valve from the stock vacuum hose. This will be reused.

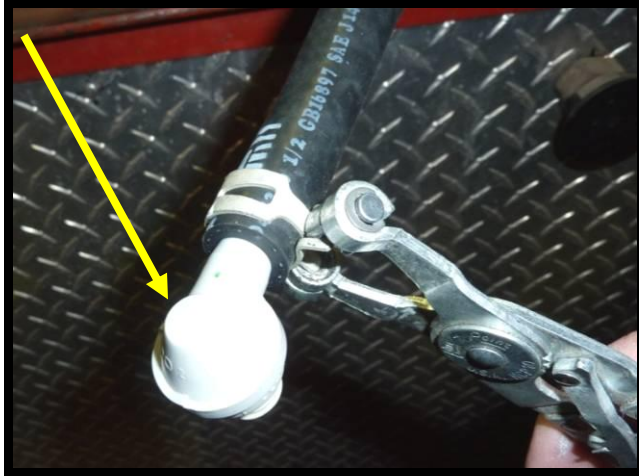

85. Remove the stock throttle body from the factory intake manifold. **NOTE:** Clean the throttle body on both the inlet and outlet sides using carb cleaner.



86. Remove the stock MAP sensor from the stock intake manifold. This will be reused.

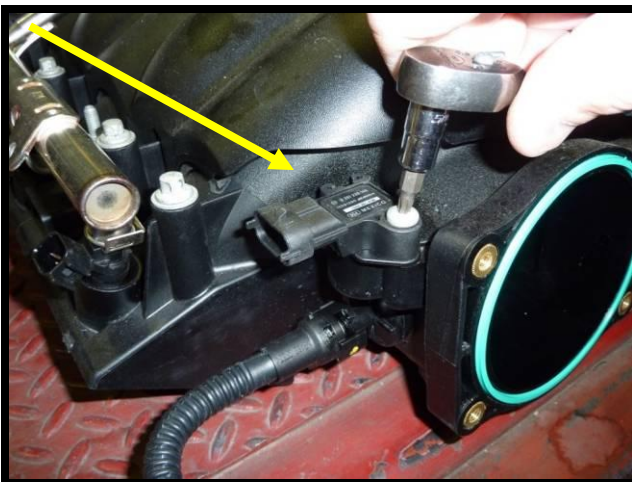

87. Install ¼" hose (F) on the Coolant Air Bleed pipe.



88. Route the hose down the factory harness and over behind the ECM. And back across the top of the fan assembly.



89. Hose (F) has a coupler in the end of the hose. Attach the FACTORY water fill neck hose to the coupler. Attach the FACTORY coolant reservoir hose back to the water fill neck.



90. Connect the Electronic Throttle Control extension cable to the factory connector and route along wires over water pump towards drivers side.



MSD FUEL PUMP VOLTAGE BOOSTER INSTALLATION:

91. Locate box with MSD Fuel Pump Booster there will be the booster module, a mounting bracket, wire harness and bolt bag. **See diagram on following page.**

CAMARO MSD FUEL PUMP BOOSTER WIRE DIAGRAM

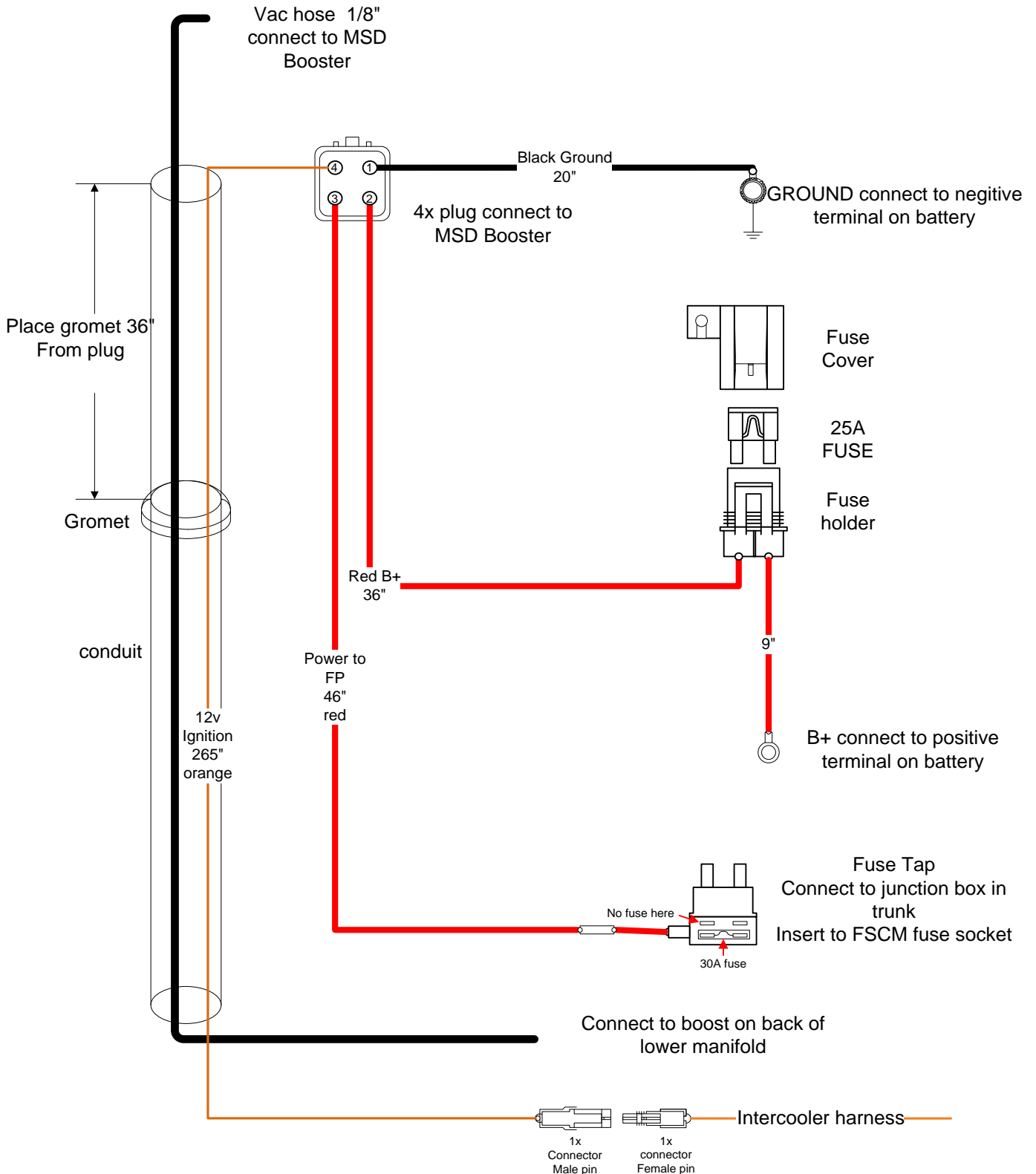

92. Remove the 6 cargo net attaching retainers. (Only hand tight).



93. Carefully pull up the weather strip molding on the trunk. Pull only the part covering the top of the panel. Remove the panel.



94. Remove these 2 plastic retainers from the panel.



95. Pull panel out and push panel forward to gain access to the rear fuse panel. Remove the cover. On the top of the cover it shows you the fuse layout.

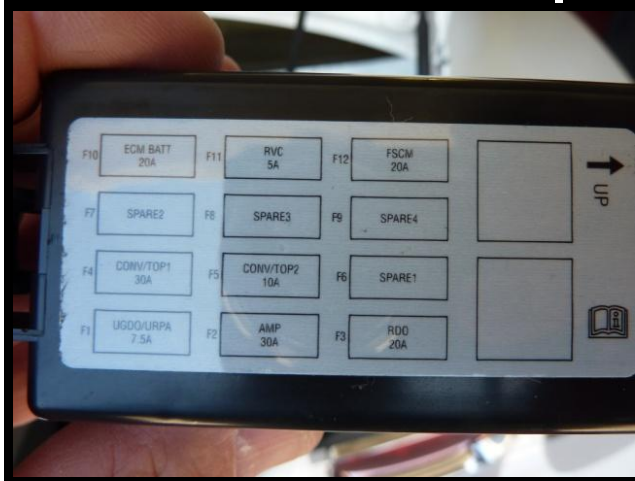
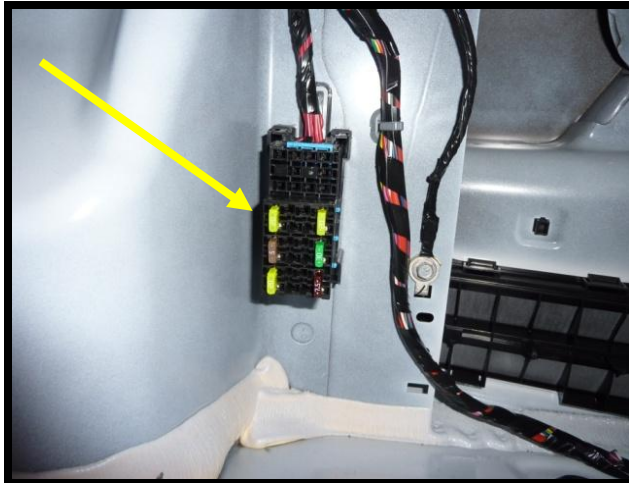

96. Remove the FSCM fuse. It will not be reused. Place it in F9 as a spare.
97. Install the FPVB (Fuel Pump Voltage Booster) support bracket on side of battery with (4) Allen bolts (9/64" Allen wrench).

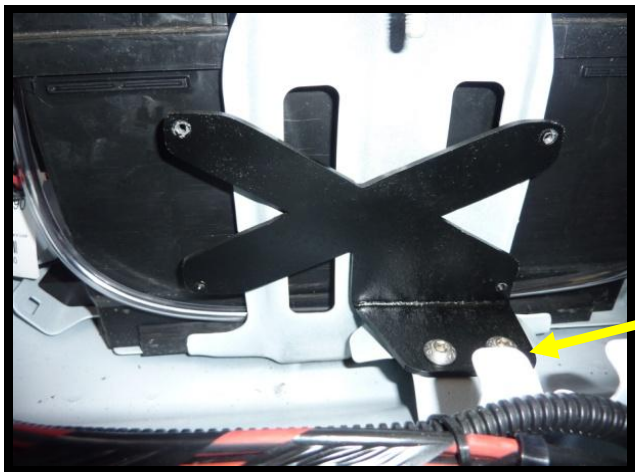

98. Lay the entire FPVB harness in the trunk. Plug in the FPVB harness into the FPVB. Including the 1/8" vacuum hose.

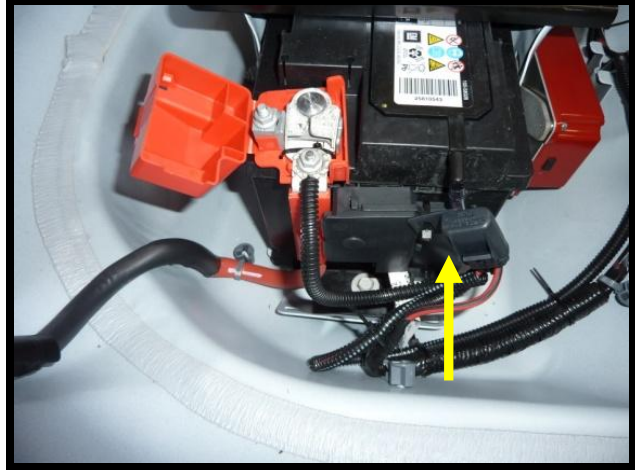

99. Attach the FUSE HOLDER red cable (POSITIVE BATTERY TERMINAL) and wire-tie the fuse holder to the battery fuse panel. Run the down the battery harness and wire tie. Notch the cover so the conduit will fit under it.



100. Route the NEGITIVE harness down the negative battery cable and attach to the battery terminal and wire-tie.



101. Route the remainder of the harness along the factory harness and wire-tie.



102. Remove the FSCM fuse (do not insert into new fuse holder) insert fuse tap from MSD as shown, it will not work turned the other way around.

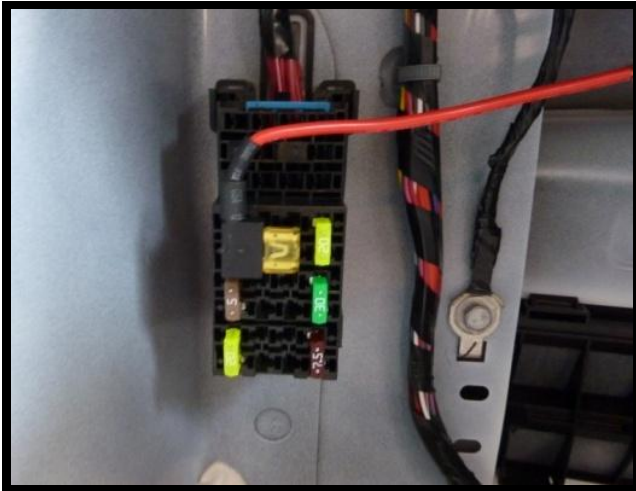

103. Notch the fuse cover to allow the harness the cover to snap into its factory location. The notch is $\frac{3}{4}$ " x $\frac{1}{2}$ ".



104. Remove the plastic body plug and route the vacuum/boost hose and the orange wire into the opening.



105. Install the harness down to the grommet, snap the grommet in place. The factory plug will not be reused.

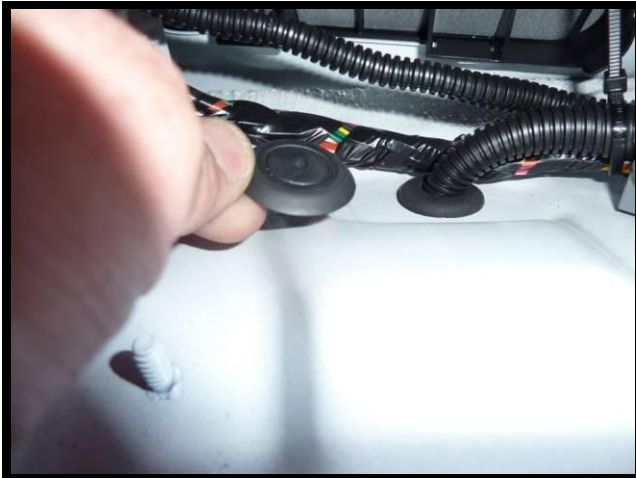

106. Route the harness on TOP of the fuel fill lines and BEHIND the factory shield. Wire tie harness to the fill tubes.



107. Route the harness down the LARGE fill tube and wire-tie to it.



108. Route the harness down the fuel tank electrical harness.



109. Remove the (4) plastic 10mm nuts and route the harness ABOVE the fuel lines. Reinstall the plastic shield.



110. Route the harness BEHIND the heat shield on right hand side of tunnel.



111. Remove the 10mm nut retaining the heat shield and route the harness through the opening and reinstall the retaining nut.



112. Route the harness along the factory oxygen sensor harness all the way up the rear of the engine. Wire tie in place along harness.

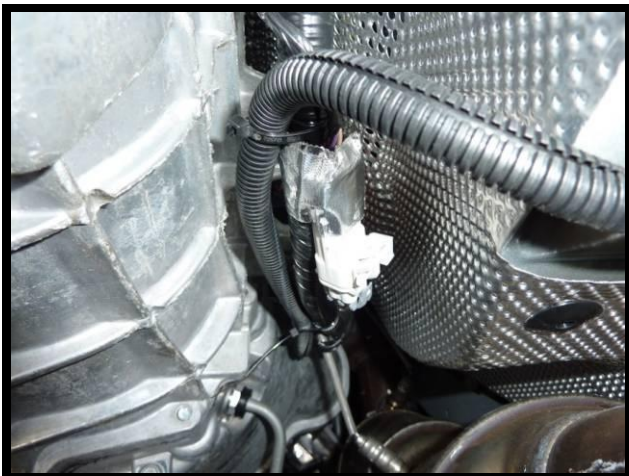

113. Route the harness over the right hand rear of the engine. Vacuum hose will be connected to port on back of new lower manifold later.
114. Route the harness along the factory harness along valve cover, then down onto frame rail.



115. Route along factory harness under the ECM.



116. Plug 1x connector into intercooler harness 1x pigtail

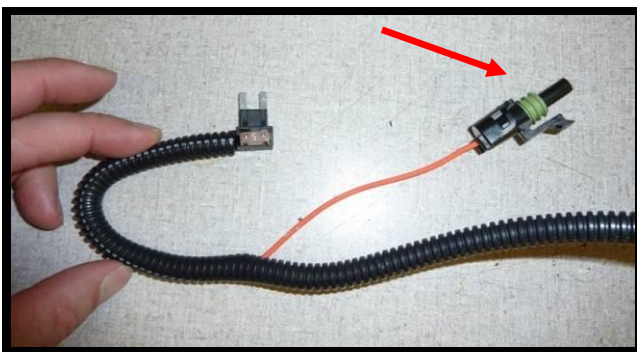

LOWER WHIPPLE INTAKE MANIFOLD INSTALLATION:

117. **NOTE:** The supercharger assembly is shipped to the customer FULLY assembled. The installer will DIS-ASSEMBLE the Supercharger from the lower manifold. The bypass actuator is left loose so the lower 2 front mounting socket head cap screws (allen) can be installed.

Supercharger Assembly

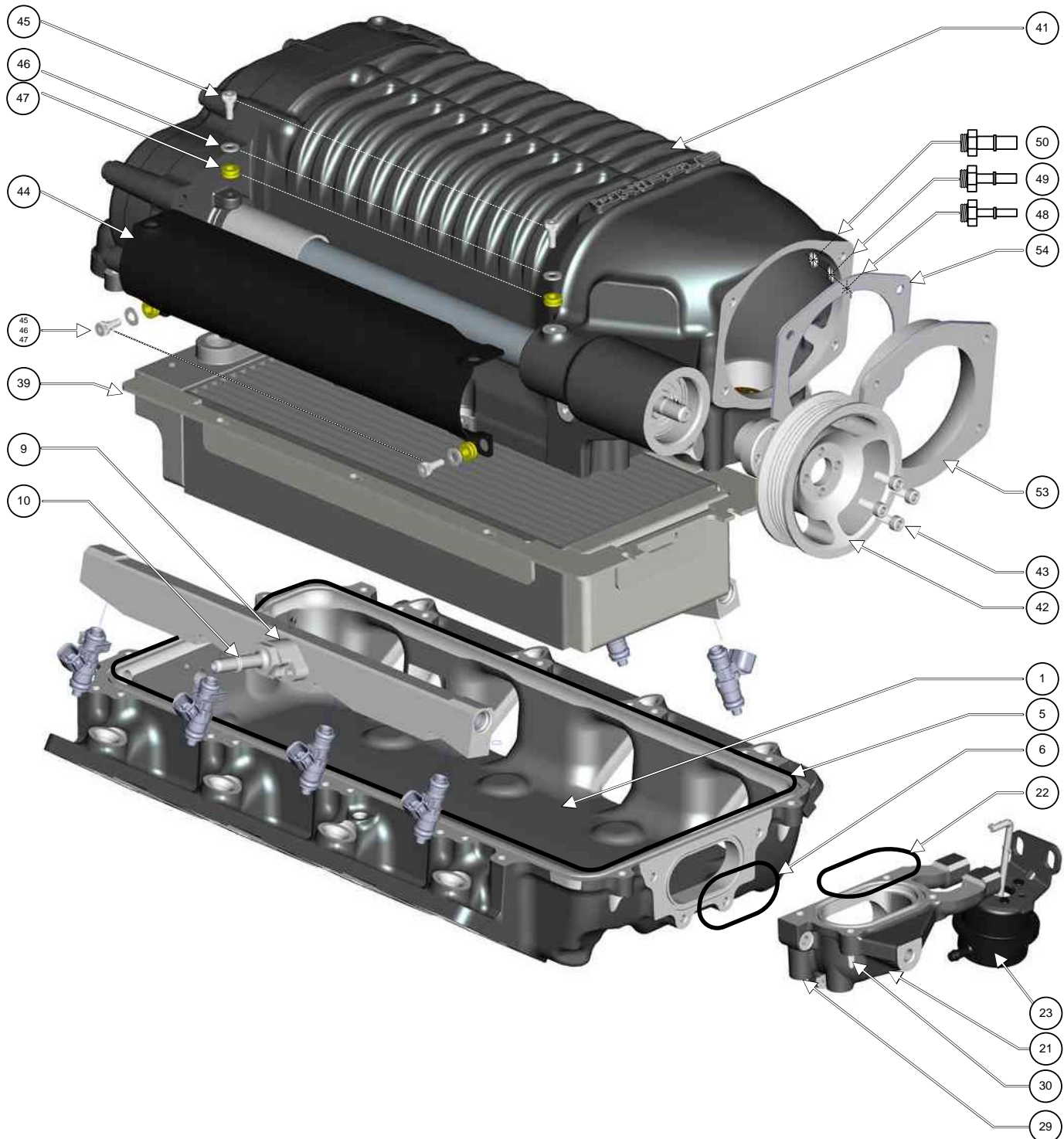

See packing list for number descriptions:

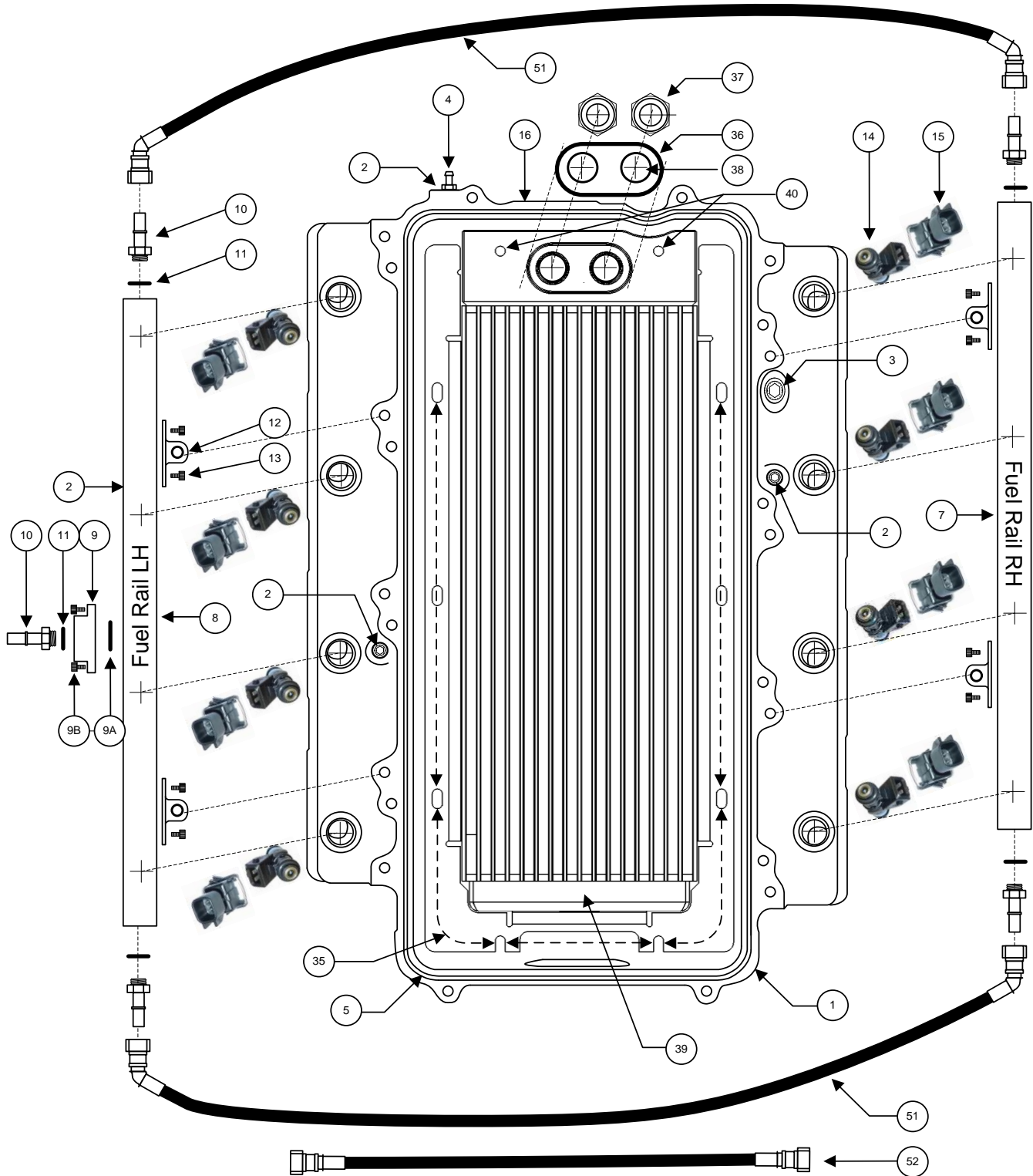

Camaro manifold bolts
Torque M6 bolts to 130 inch pounds

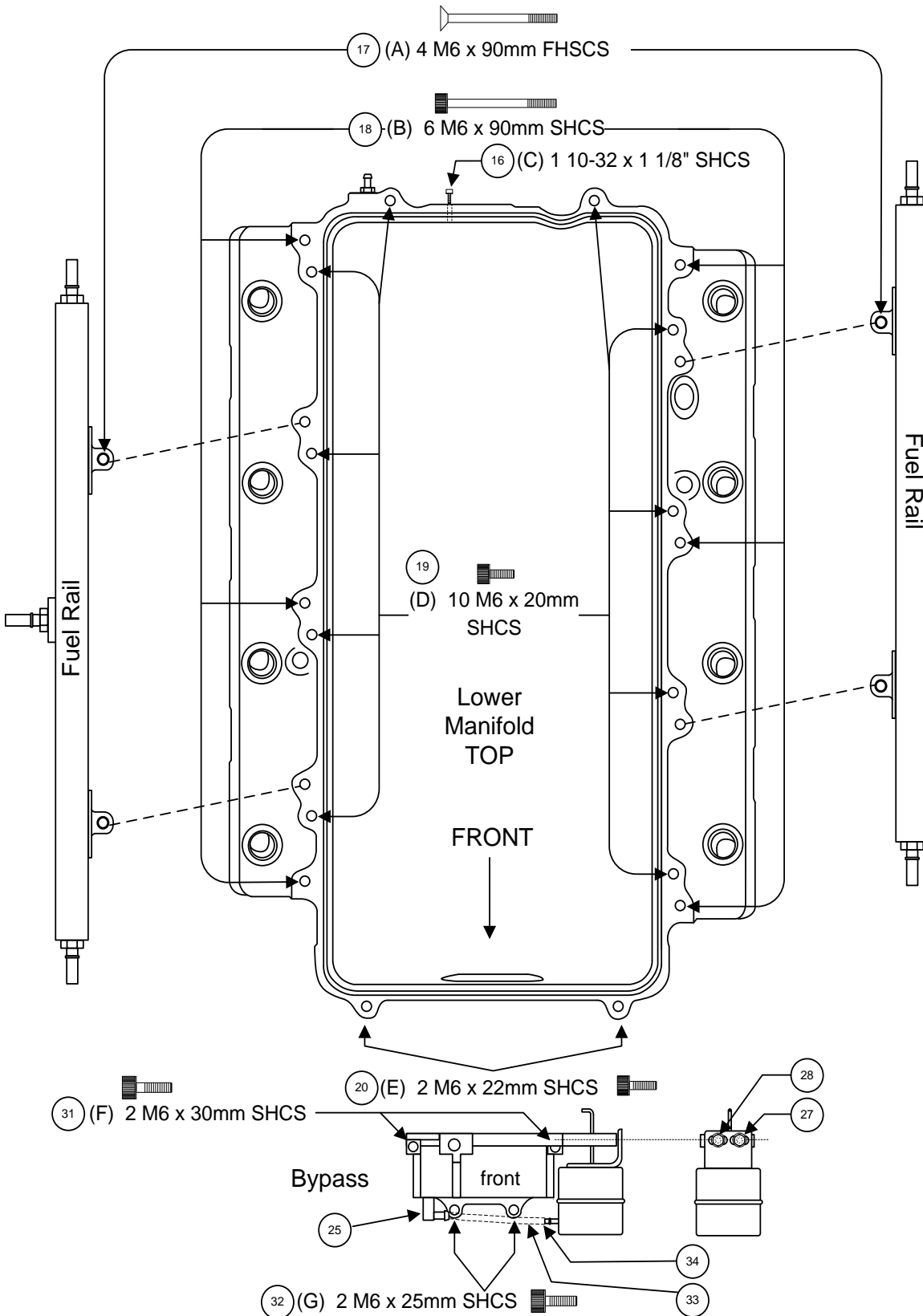

118. Install the factory MAP sensor in the rear of the Whipple Supercharger manifold with the provided 10-32 x 1 1/8" SHCS bolt (C). **NOTE:** Apply a small amount of lubricant on the O ring. Attach the MAP extension harness to the sensor. Attach intake air temp sensor extension harness to sensor located on back of intake manifold.



119. Install the Lower intake port O rings, when the O ring is installed correctly it will lay FLAT in the groove. Note: if you twist the O ring it will cause a vacuum leak. (DTC P0171 OR DTC P0174 or both).



120. Remove the tape from the ports, clean the ports with a CLEAN cloth and spray the cylinder head intake surface with silicone or soapy water. It will allow the Lower Intake manifold to slide around. Place the lower intake manifold on the cylinder heads. DO NOT install any bolts.



121. Connect vacuum line from BAP to nipple on back of blower manifold trim as necessary.

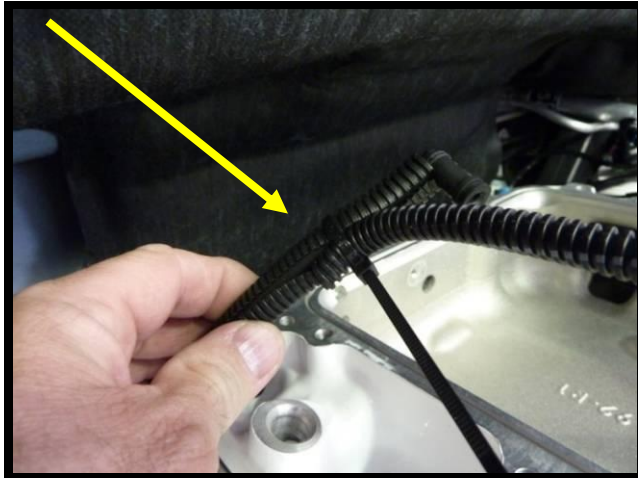

122. Due to the placement of the PCV orifice tube in the valley cover plate the lower intake relief SOMETIMES comes in contact. Insert a cross point (Phillips) screwdriver into the tube and VERY carefully move the tube away from the contacting point on the lower manifold.



123. Remove the vacuum plug from the bank1 (driver side) valve cover (in the rear). Install it on the tube.

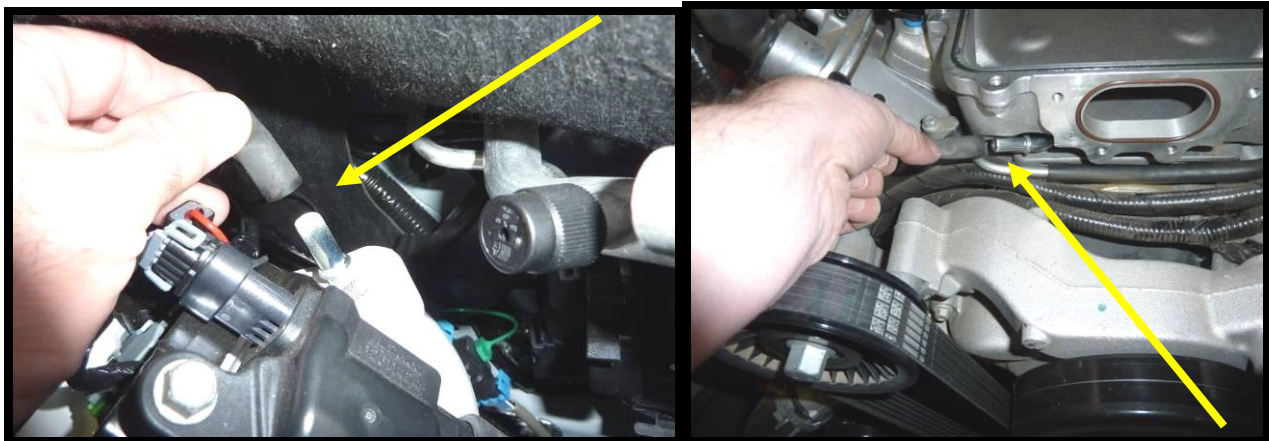

124. Install the Lower retaining bolts (A) (4) M6 x 90mm FHSCS through fuel rail brackets and (B) 6 M6 X 90mm Allen In the Lower manifold (See bolt diagram page 48) and torque first pass in sequence to 44 inch pound, second pass to 89 inch pound . Final pass to 130 inch pounds. **NOTE:** Torque bolts from side to side, starting from the middle bolts. Cover the intake with a clean drop cloth.

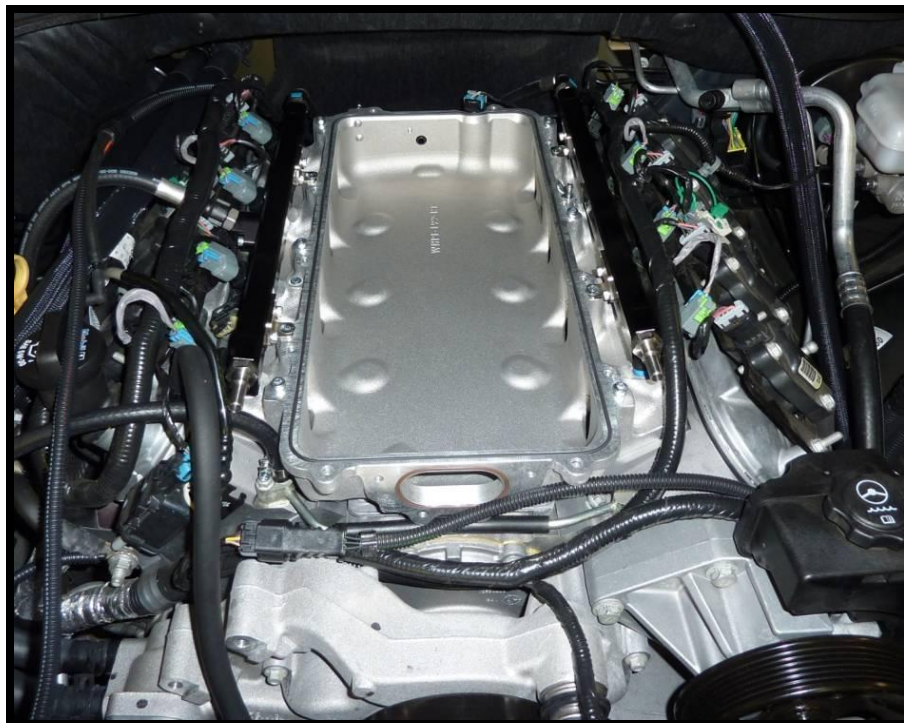
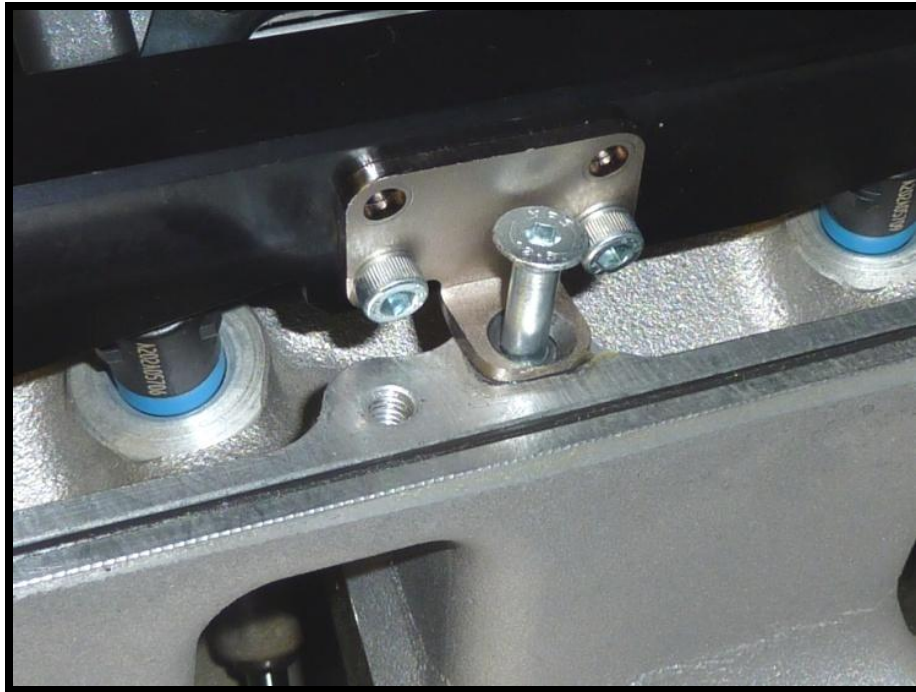

SUPERCHARGER OIL FILLING:

125. The supercharger must be filled with oil prior to use. This supercharger is shipped without oil inside. The oil is in a separate bottle supplied with your kit

!! CAUTION !!

Severe damage to the compressor will occur if you overfill the supercharger rear gear case.

- Make sure the SC is sitting on a flat surface.
- Remove -6AN allen plug (1/4" allen wrench) and fill SC with **WHIPPLE SC OIL ONLY!!**
- Fill to the middle of the sight glass. Tip from side to side then with flat check oil again add as necessary.
NOTE: The W175FF compressor takes a maximum of 8 fl/oz.
- Reinstall -6AN allen plug.
- NOTE: After running the SC, the oil level will lower due to oil filling the bearings. The proper level while **not running** should be between the bottom of the sight glass and the middle and will vary when running and not running.
- Change SC oil every 100,000 miles and only use **WHIPPLE SC OIL ONLY!!**

!! CAUTION !!

Severe damage to the compressor will occur if you overfill the supercharger rear gear case.

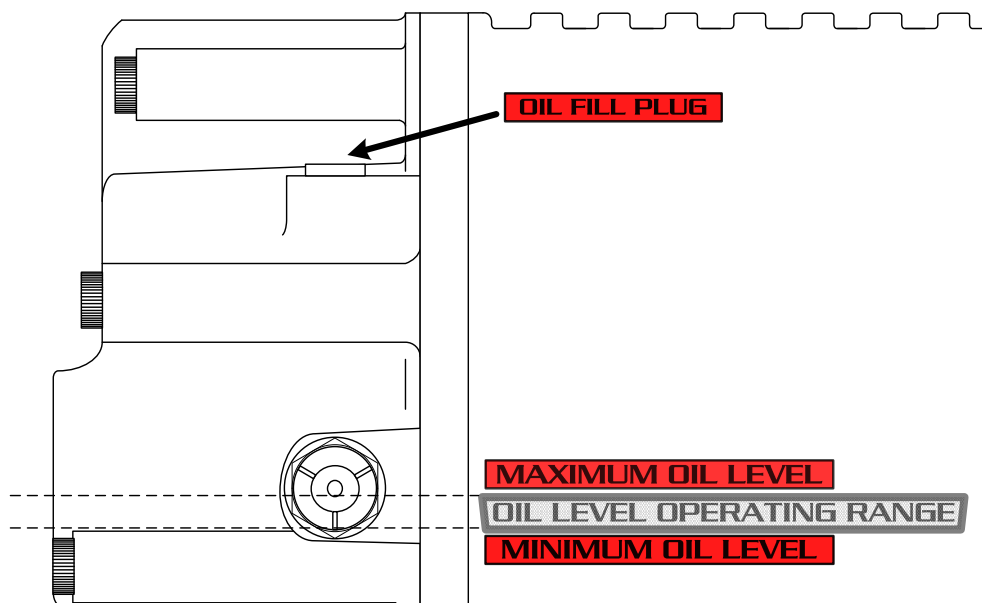
**!! CAUTION !!**

Severe damage to the compressor will occur if you overfill the supercharger rear gear case.

126. Pre fill intercooler core through water fitting before installing on manifold this will make it easier to get bubbles out of system.
127. Install the coil pack assembly and torque the bolts to 106 inch pounds. **NOTE:** DO NOT forget to plug in the coil connectors.
128. Plug in fuel injectors. **NOTE:** injectors will have connector adapters already installed.

129. Rest S/C assembly on front of lower manifold and attach intercooler lines (D) & (E) to back. Use 1" wrench.



130. Carefully set blower in position and slide under cowl. (Note it may be necessary to pick up cowl slightly).



131. Once S/C assembly is down slide back until bypass is against front of lower manifold (Note if S/C wont slide back all the way you may need to lift rear up slightly while you slide it back to get it over the rear fuel rail bolts).

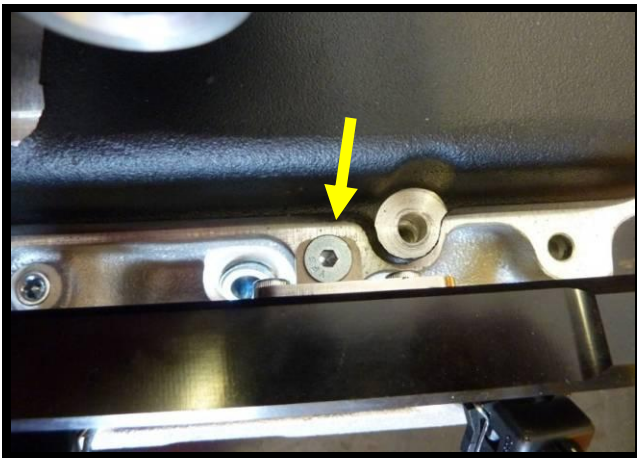

132. **NOTE:** Make sure that the vacuum actuator does NOT contact the water pump when you install the supercharger. Remove the (2) M6 SHCS from the actuator bracket & loosen clamp on vacuum line. This is to gain access to the (2) attaching bolts from the bottom of the lower manifold step 134.



133. Install front bypass bolts (2) M6 x 25mm SHCS bolts TOP POSITION (F) and (2) M6 x 22mm SHCS bolts in the lower position (G). Torque to 106 inch pounds. (See bolt diagram page 49).

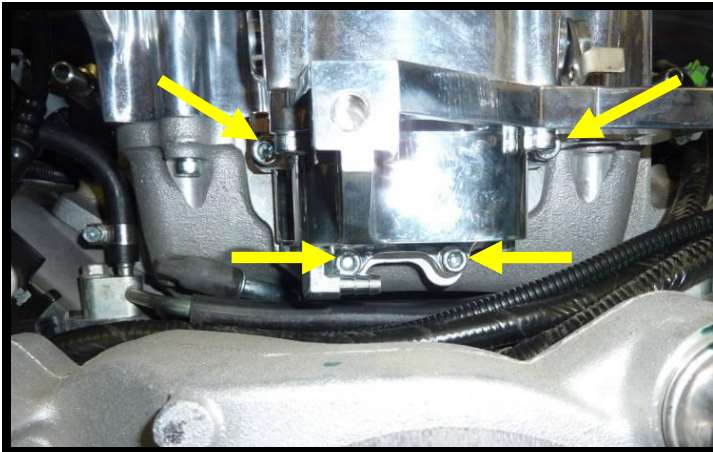

134. Install (2) M6 x 25mm SCHS (E) bolts on both sides tighten with a 5mm Allen wrench (see bolt diagram page 49)

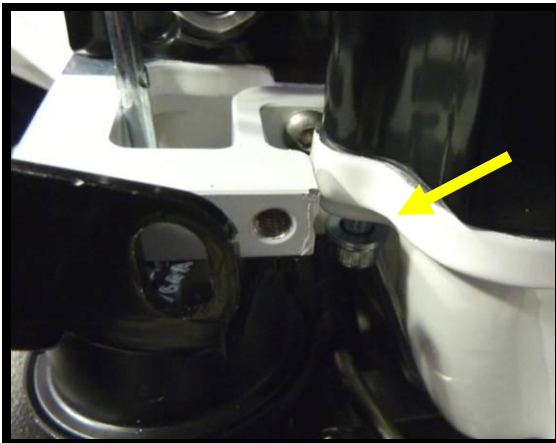

135. Install 10 M6 x20mm bolts (D) bolts (see bolt diagram page 49) Installing the attaching bolt that is under the gear case housing is installed with mechanical fingers. Tighten with a 5mm ball allen. Torque to 106 inch pounds. Torque all perimeter bolts to 106 inch pounds.



136. Adjust the actuator by pulling up on the bottom so that the lever is against the stop. Torque the bolts to 106 inch pounds. NOTE: After adjusting, open the bypass with your finger by pulling the bypass lever down. If the lever is stuck bend the lever up SLIGHTLY, just enough to not stick. If you bend it too much it will bleed off boost. This is not common so notify Whipple if this is found.



137. Install the Fuel Feed Hose between chassis and engine. Install front fuel line around front of blower to fuel rails (AVON CADbar 9000 series hose).

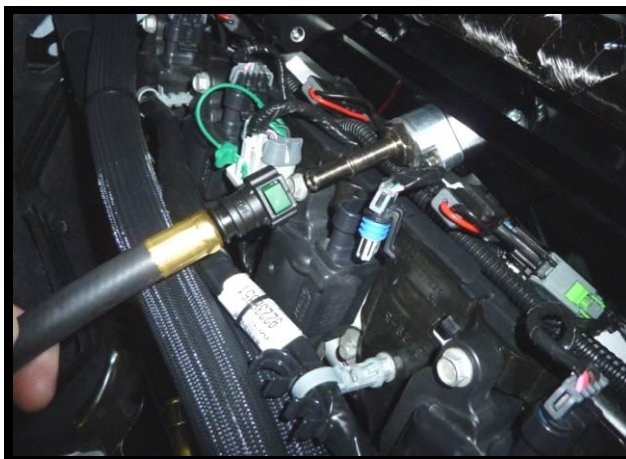

138. Attach the OE Purge hose from Purge Solenoid to the 5/16" quick disconnect fittings. **NOTE:** Route the OE line UNDER the throttle body. Reinstall the OEM Purge hose from tank.

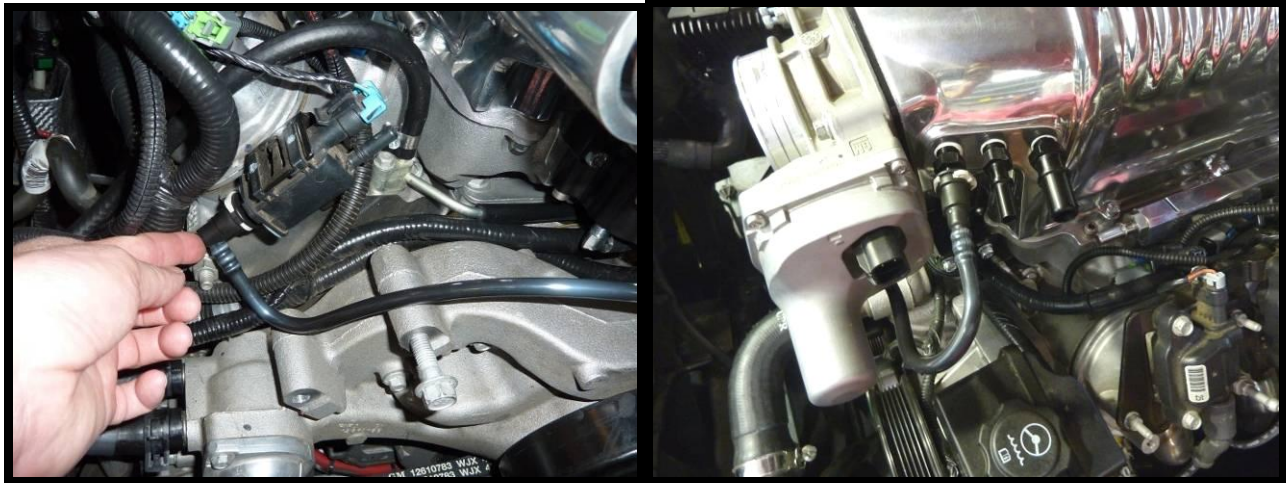

139. Install the Brake vacuum check valve and clamp in the 11/32" hose with the quick disconnect fitting. Plug into the brake booster and route line to supercharger inlet and connect quick connect.



140. Install the 3/8" PCV quick disconnect fitting on the rear of the driver side valve cover, install the other connector at the supercharger inlet on the middle port.

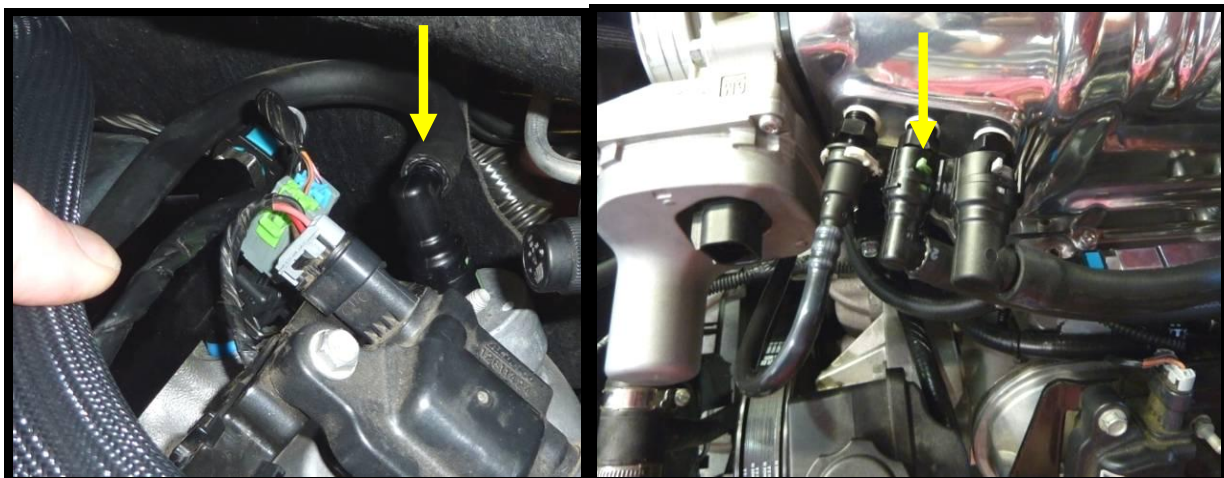

CAMARO FRONT IDLER PLATE

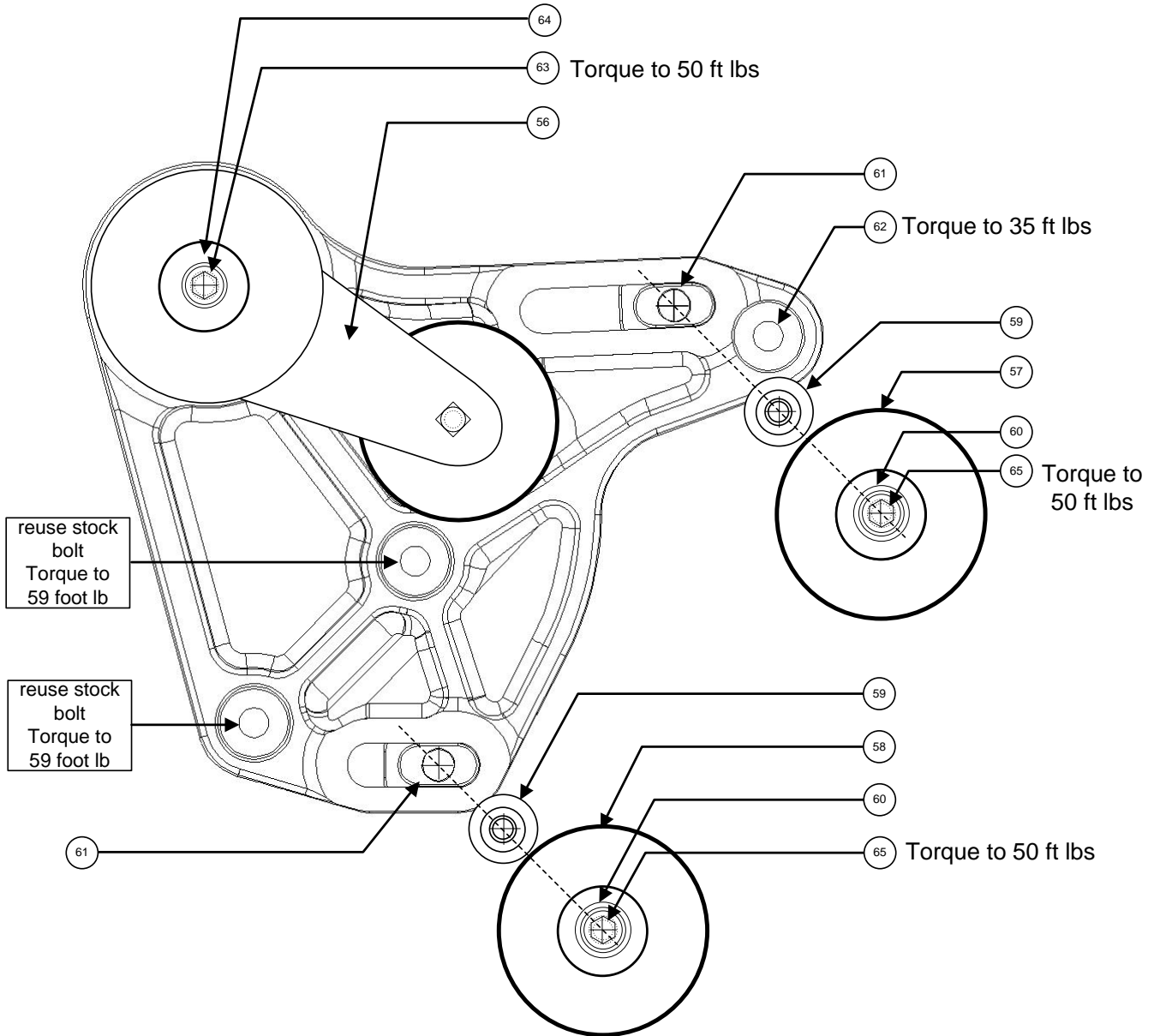

141. Install the tensioner plate by installing the OEM bolts and M10 X 20mm HEX HEAD FLANGE BOLT (62). This bracket bolts where the OE tensioner was located. Bolt (62) is installed in the bypass adapter. Torque both OE bolts to 59 foot pounds and the socket cap bolt (62) to 35 foot pounds.

142. Install the smooth idler and the ribbed idler with the bolt and sliding (TEE) nut. **NOTE:** Leave bolts loose until belt install. Install tensioner and torque bolt to 50 foot pounds.



143. Install belt wrap belt per illustration on next page hold back spring loaded tensioner and slip belt onto water pump pulley.

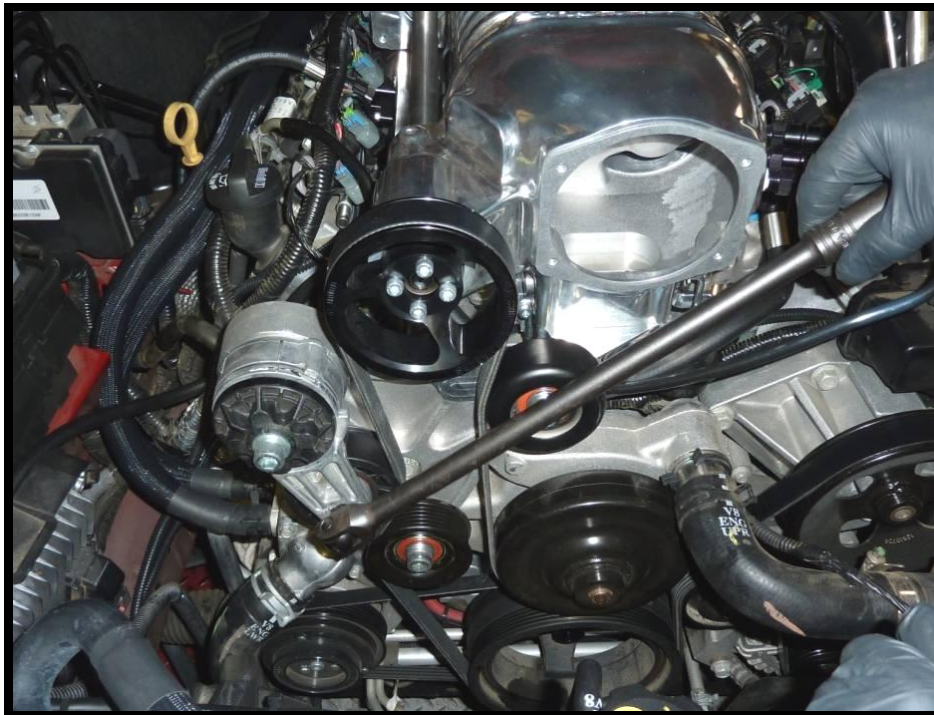

CAMARO BELT ROUTING

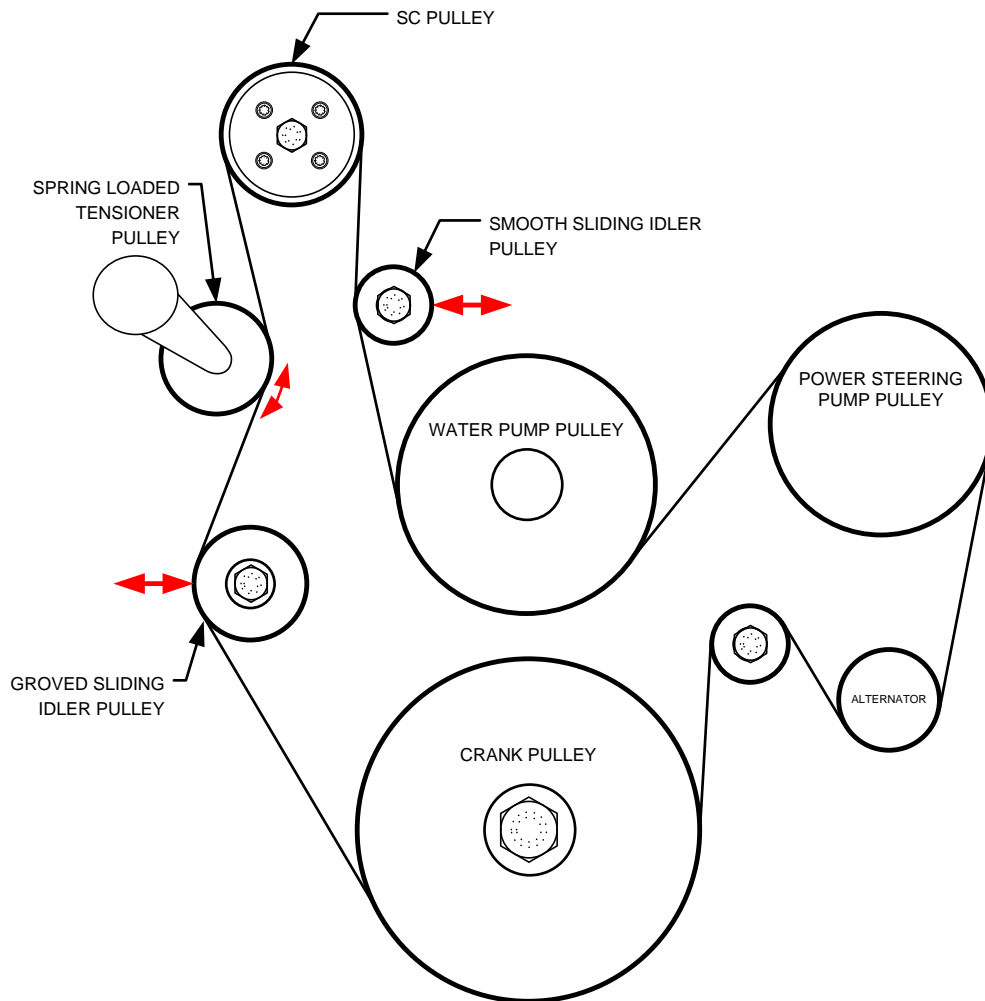

144. Adjust the ribbed sliding idler so that the belt tightness on the tensioner MAXIMUM adjustment lines match, after 25 miles re-adjust the belt tension with both idlers. Torque bolts to 50 foot pounds.

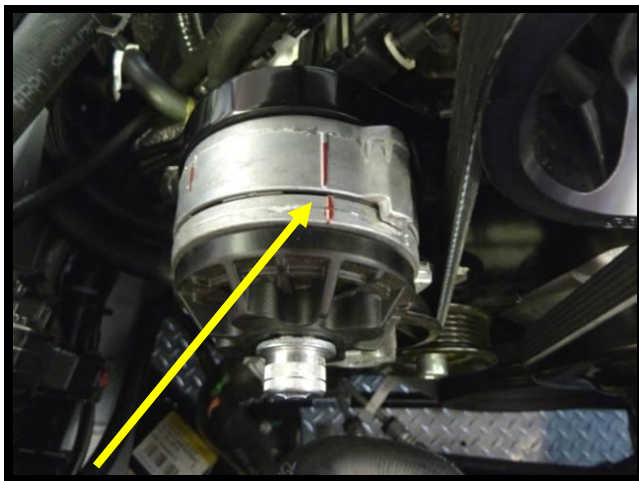

145. Install the throttle body (with billet venturi and gaskets) with the provided (4) M6 X 50MM SHCS bolts and torque to 89 inch pounds.



146. Plug in Electronic Throttle Control (ETC) extension connector.



INTAKE AIR TEMP SENSOR WIRING INSTALLATION:

147. Find MAF sensor main plug, remove tape and pull back conduit to expose about 10" of wire.



148. Remove pin retainer on front and back of plug.

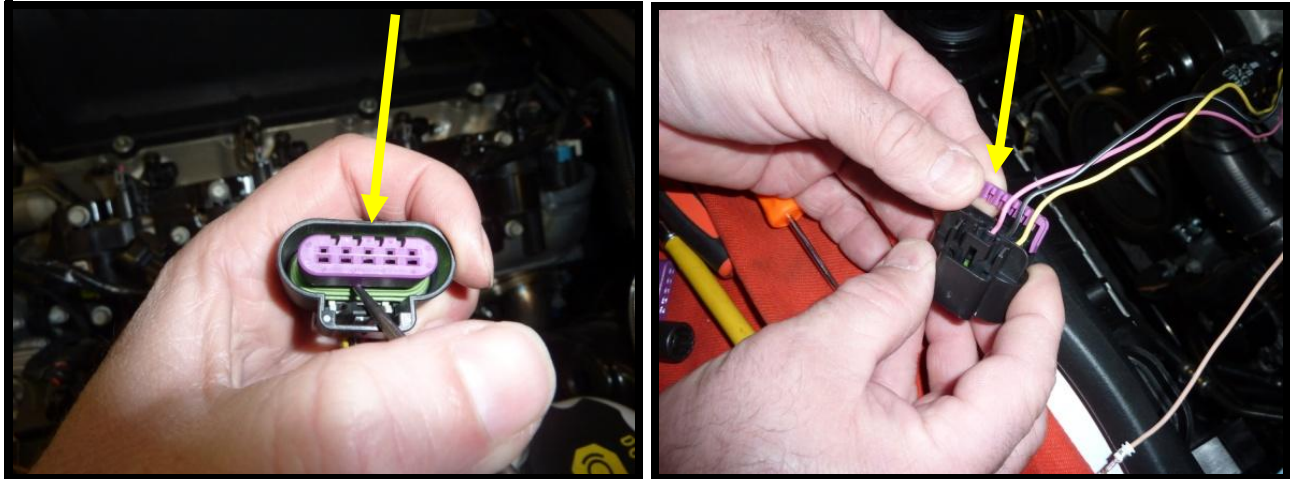

149. Pull IAT sensor pins D & E out back of plug, Use a pick to pull tab away from terminal to release and push terminal out the back.

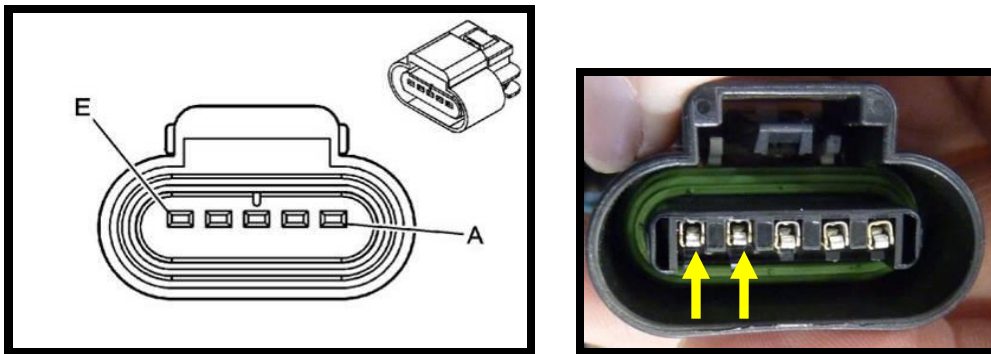

B75B Mass Air Flow/Intake Air Temperature Sensor (L99 or LS3)

Pin	Wire	Circuit	Function
A	0.5 YE	492	MAF Sensor Signal
B	0.5 BK/WH	451	Ground
C	0.5 PK	239	Ignition Voltage
D	0.5 TN	2760	Low Reference
E	0.5 L-BU	6289	Intake Air Temperature Sensor Signal

150. Insert green cavity plugs provided into empty holes (D and E).

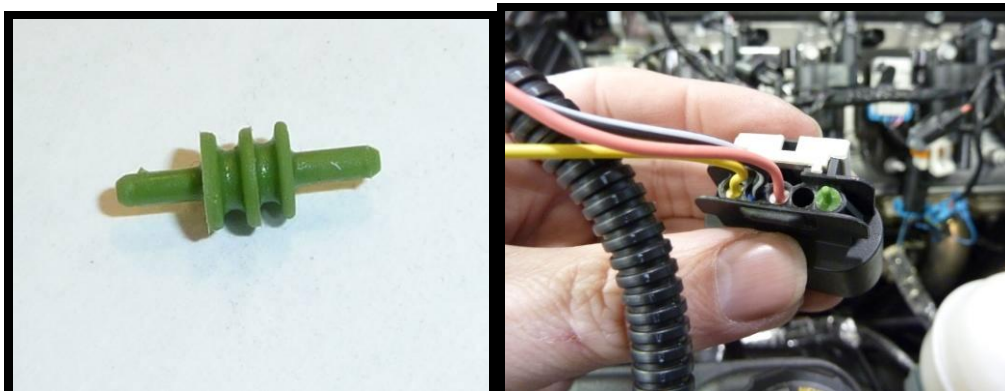

151. Reinstall pin retainers on front and back of MAF plug.

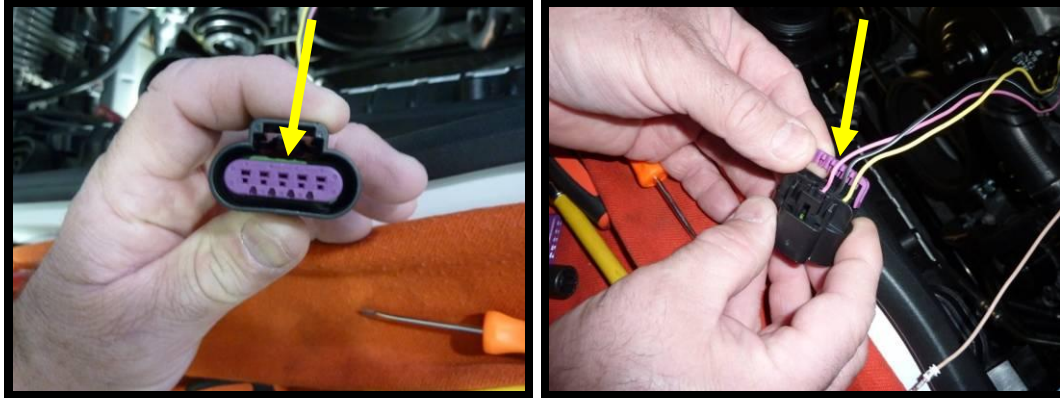

152. Insert IAT pins into the back of new 2 pin plug that came with IAT extension harness (they should click in), then push purple pin retainer clip down to lock pins in.



153. Fold IAT wires over and run back towards the IAT extension then recover wire harness with conduit. Plug in IAT extension.

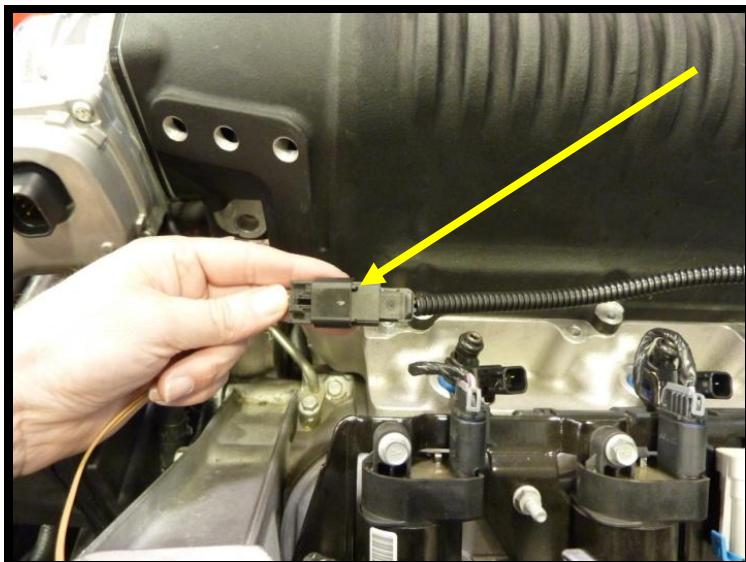

INTERCOOLER RESERVIOR (DEGAS) INSTALLATION:

154. Remove right hand upper fan shroud bolt and radiator support bolt.
155. Place intercooler bracket on radiator mounts as shown, then reinstall bolts.

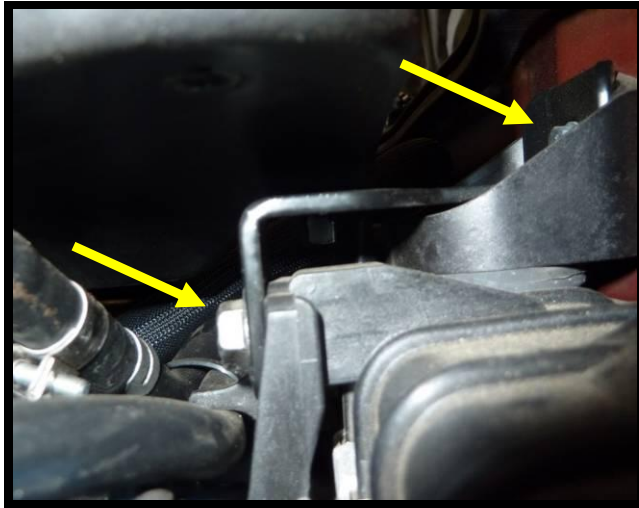

156. Connect hose (E) to right hand of tank and hose (D) (see diagram page 11).



157. Run hose (D) across top of radiator and connect to hose (B) (see diagram page 11).



FACTORY AIR BOX MODIFICATION INSTALLATION:

158. Modification to the LOWER air box. (This is a 25 horsepower and a 1.2 psi boost increase. (At 70 degrees).
159. Starting at the corners using a 3/8 drill bit, drill the lower corners of the air box. Here is the lay out of the drilled holes and the pattern to remove.



160. Drill hole 4 from inside right in corner of ribs



161. With the hand hacksaw provided (or power saw) cut connecting the dots. If necessary double drill holes at beginning of cut to make room for saw blade to start. Cut sections between 3, 4 & 5 from inside follow along ribs.



162. Remove the cut out portion of the box. Using a hand file smooth all the rough edges.



163. Using 120 grit sandpaper smooth all the edges. Blow clean when done.



FACTORY AIR BOX INSTALLATION:

164. Install the Lower Air Box, K&N Filter, Upper Air Box, hoses and Intake Duct. **NOTE:** The HUMP hose installs on the MAF side and the reducer hose installs on the Throttle Body. Tighten the hose clamps. **DO NOT CRUSH** the Air Intake by **OVER** tightening the clamps.



165. Install the PCV Vent line (snaps in place) on passenger side valve cover then install other end to the 90 Degree fitting in the grommet on the air duct between the throttle body and the MAF. Route the PCV vent hose parallel to the radiator hose so the hose will NOT come in contact with the Drive Belt.

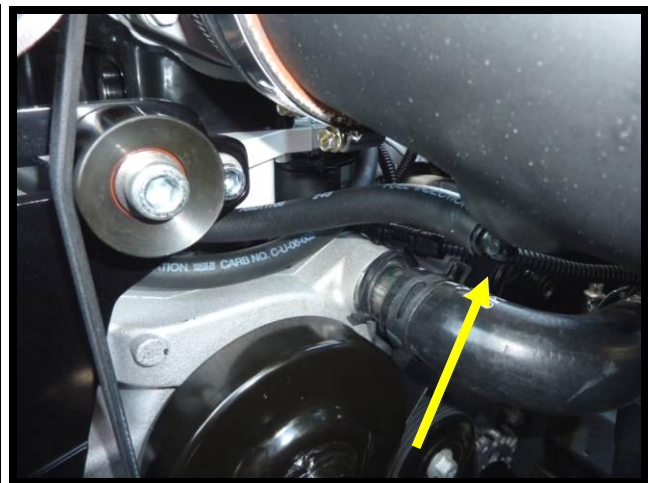
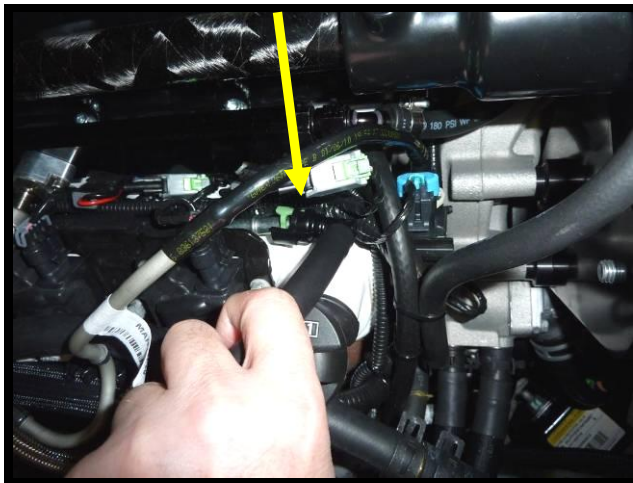

166. Refill the Engine coolant. Verify that your coolant drain is closed, and use a filter/strainer to pour the recycled coolant/water mixture that you drained from the radiator. If necessary top off with a **GM approved engine coolant**. Whipple also recommends running 2 bottles of Redline Water Wetter which can be found at most automotive parts stores. **⚠ WARNING!! DO NOT USE TAP WATER OR ANY NON GM APPROVED ENGINE COOLANT, THIS WILL CAUSE CORROSION IN THE SYSTEM.** Start engine to completely fill system.

167. Fill the Intercooler tank with a 50/50 mix of antifreeze (Dexcool). NOTE: Use ONLY DISTILLED water for the 50/50 ratio with Dexcool. Whipple also recommends running 1 bottle of Redline Water Wetter in the intercooler. 
WARNING!! DO NOT USE TAP WATER OR ANY NON GM APPROVED ENGINE COOLANT, THIS WILL CAUSE CORROSION IN THE SYSTEM.



168. Attach the negative cable to the battery and tighten.



169. Turn the Ignition key on DO NOT START THE ENGINE (This will turn ON the fuel pump for 2 seconds) Inspect for ANY leaks fuel, coolant, and intercooler coolant, correct as required.
170. Start the engine and let it idle. The engine should idle normally between 600-700 rpm. Inspect for leaks. After running for 2 minutes turn off engine and inspect the level in the ENGINE radiator and the Intercooler tank. With the key in the ON position engine off, inspect the coolant in the intercooler tank , the coolant should flow in the tank. If it does NOT the coolant circuit has an air pocket trapped in it . To remove the air pocket insert an air blow nozzle in the top of intercooler tank and wrap a clean cloth around the end of the nozzle and around the top of the tank and slightly pressurize the tank, this will force the trapped air out of the system. Add coolant to fill the system.

171. Before driving make SURE that you have 91 or BETTER octane fuel in the system. NOT ½ tank of 87 and ½ tank of 91, ALL 91 or better fuel in the system. DO NOT USE ANY OCTANE BOOSTER IN THE FUEL.
172. DO NOT use ANY aftermarket air filter box or duct with the supplied Whipple calibration. The Whipple calibration is designed to work with the factory air box, factory MAF and Whipple air inlet duct and nothing else. Changes to the air inlet system will require a custom tune which Whipple does not provide.
173. Attach the "Use Premium Fuel Only" decal to the gas tank fill cap or door.
174. Install the supplied 50-state legal sticker to factory radiator shroud.
175. Test drive vehicle for the first few miles under normal driving conditions. Listen for any noises, vibrations, engine misfire or anything that does not seem normal. The supercharger does have a slight whining noise under boost conditions, which is normal.
176. Re-check the radiator and intercooler reservoir coolant level regularly over the first 1,000 miles, top off level as needed.
177. After the initial test drive, go through the belt tensioner process again. When next you start driving, gradually work the vehicle to wide open throttle runs. Listen for any engine detonation (pinging). If engine detonation is present, let up on the throttle immediately. Most detonation causes are low octane gasoline still in the tank.
178. If you have questions about your vehicles performance, please check with your installation facility or call Whipple Superchargers at 559.442.1261, Monday through Friday from 8am to 5:00pm, pacific time or email questions to tech@whipplesuperchargers.com.

⚠ WARNING!! Verify the bypass actuator is working properly. To monitor, look at the bypass arm when the motor is not running. Start engine and verify that the actuator arm has opened. This arm will be extended when the engine is above 1" of vacuum (boost) and will be open when there is more than 1" of engine vacuum.

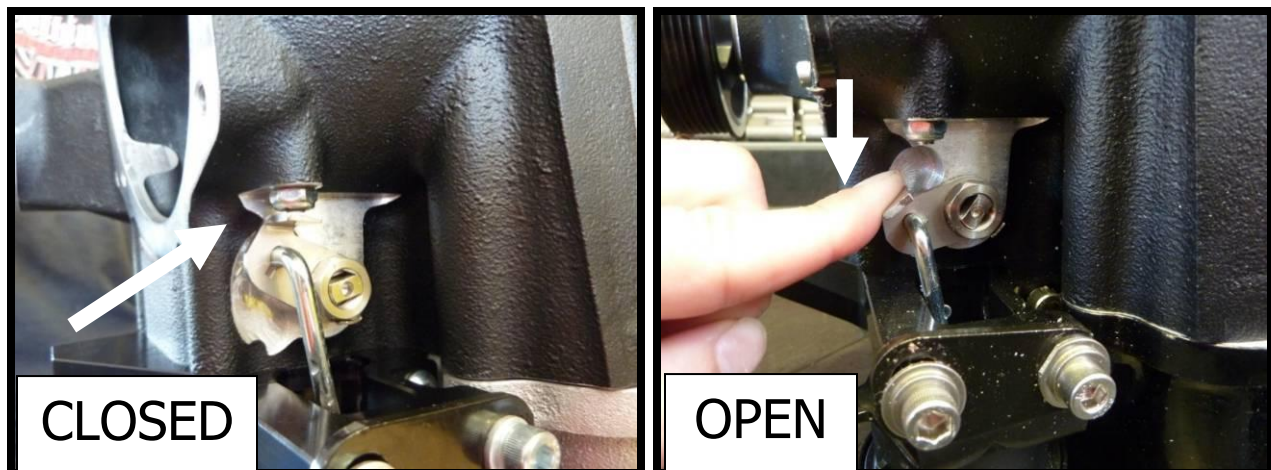

Maintenance and Service

Be sure to follow the maintenance and service recommendations below to optimize the life and performance of your Whipple-supercharged vehicle.

For best performance and continued reliability it is essential to adhere to the following guidelines:

1. Use only premium grade fuel (91-octane or higher).
2. Always listen for any sign of spark knock or pinging. If present, discontinue use immediately and consult your vehicle owner's manual.
3. Do not operate the vehicle at large throttle opening if the MIL lamp is on steadily. This indicates an electronic engine control malfunction: reduce throttle opening and consult your vehicle dealer.
4. Check the supercharger oil level at every engine oil change. Add Whipple SC oil to the supercharger if required. Do not overfill the supercharger rear gear case.
5. Change the oil in the supercharger every 100,000 miles. Use Whipple SC oil only.

!! CAUTION !!

Severe damage to the compressor will occur if you overfill the supercharger rear gear case.

6. Do not operate the vehicle at large throttle opening if the MIL lamp is on steadily. This indicates an electronic engine control malfunction: reduce throttle opening and consult your vehicle dealer.
7. Inspect and clean your high-flow air filter element every 7,500 miles.
8. Inspect and replace spark plugs every 20,000 miles. Only run specified plugs such as NGK TR7IX.
9. Follow your factory service intervals for oil changes and other typical maintenance items.
10. Check the supercharger/accessory drive belt. Adjust or replace as required

!! CAUTION !!

Any modification to your vehicle's new computer program may cause serious damage to the engine and/or drive train.

6.2L PULLEY/BELT MATRIX

Pulley size	Belt size	Notes
4.125	96.2" 6 rib	
4.000	96.2" 6 rib	
3.875		
3.750		
3.625		

NOTE: Torque pulley to 130 inch lbs



LIMITED WARRANTY

All merchandise manufactured by Whipple Industries has a limited warranty against defects in workmanship and materials to the original purchaser of the Whipple Supercharger System for one calendar year from Whipple Industries ship date. The limited warranty must be signed, dated and returned to Whipple Industries within 30 days of the Whipple Industries ship date and must be accompanied by a copy of the original sales invoice. This warranty is non-transferable.

If an item is suspected of being defective, return it to Whipple Industries for inspection after obtaining the proper Return Authorization Number. If an item is determined to be defective, we will repair or replace it at our discretion within a period of one year from the shipping date on your invoice.

Whipple Industries Inc. limited warranty specifically does not apply to products which have been (a) modified or altered in any way, (b) subjected to adverse conditions such as misuse, neglect, accident, improper installation or adjustment, dirt, or other contaminants, water, corrosion or faulty repair; or (c) used in other than those specifically recommended by Whipple Industries Inc. All products designed for off-road use are considered racing parts and carry no warranty, either expressed or implied, as we have no control over how they are used.

On warranty items, repair/replacements will be limited to parts manufactured by Whipple Industries and will not include claims for labor or inconvenience. All other merchandise distributed by Whipple Industries is warranted in accordance with the respective manufacturer's own terms of warranty. This warranty is expressly made in lieu of any and all other warranties expressed or implied, including the warranties of merchantability and fitness.

Whipple Industries will not be responsible for any other expenses incurred by the customer under the terms of this warranty, nor shall it be responsible for any damages either consequential, special, contingent, expenses or injury arising directly or indirectly from the use of these products.

Whipple Industries reserves the right to determine whether the terms of the warranty, set out above, have been properly complied with. In the event that the terms are not complied with, Whipple Industries shall be under no obligation to honor this warranty. By signing this form, you understand and agree to the terms above.

NAME (Print) _____ ADDRESS _____

SIGNATURE _____ CITY _____ STATE _____ ZIP _____

DATE _____ PHONE _____

SC SERIAL # _____ EMAIL _____
(Found on compressor bearing plate) (Optional)

VIN # _____

CONGRATULATIONS

Your new Whipple Supercharger is engineered to significantly increase your engines power across a broad range of RPM's. It is Whipple's goal to improve your driving experience for many miles and years to come.

Whipple Superchargers operate as an air pump and contain internal rotors that are driven by the engine's crankshaft and serpentine belts. The supercharger compresses outside air and channels it into the engine's intake ports. Because of their design, superchargers may generate some additional noise over the standard, normally aspirated induction system.

At idle, you may hear a medium-pitch rattle from the supercharger main housing. This will diminish at about 400-500 rpm above idle.

You may also experience a muffled high-pitched whine during acceleration. This is caused by the pumping action of the supercharger compressing air and only occurs during boost conditions. It is inaudible during part-throttle acceleration.

These are normal noises associated with any supercharger and have no effect on supercharger performance or engine durability.

Your supercharger is warranted by Whipple Superchargers, please see your terms and conditions on the back of your invoice for more information in regards to the limited warranty. NOTE: Whipple Superchargers will not authorize any warranty repair work or supercharger replacement for normal noise